



FAG



added
competence

Rolling Bearings for Textile Machinery

SCHAEFFLER GROUP
INDUSTRIAL

Foreword

Schaeffler Group Industrial is a leading worldwide supplier of rolling bearings, spherical plain bearings, plain bearings, linear products, accessories specific to bearings and comprehensive maintenance products and services. It has approximately 40 000 catalogue products manufactured as standard, providing an extremely wide portfolio that gives secure coverage of applications from all 60 designated industrial market sectors.

Economical solutions for textile machinery

Schaeffler Group Industrial offers manufacturers of textile machinery a comprehensive range of precision products for the reliable and cost-effective support of rotary and linear motion. Increasingly, there is a requirement for inventive and cost-effective solutions that often cannot be met simply by using “off the peg” bearings. As a result, system components matched precisely as complete systems to the specific application are increasing in importance.

This development is also reflected in this publication “Rolling Bearings for Textile Machinery”: In this publication, you will find a significantly larger number of application examples using dedicated solutions for textile machinery than in the past. Behind every one of these solutions lie many years of knowledge and experience in the textile machinery industry.

The first few pages of the publication present high quality standard bearings that reliably perform their duty in many applications. In many cases, these bearings allow highly economical solutions and are readily available.

Energy-efficient bearing arrangements

The energy consumption of machinery can be reduced by means of smaller masses and lower friction. Schaeffler Group Industrial is also working on the development of new bearings and units from this perspective. One example of such a unit is the new thread guidance roller FRM.

Development partner

The engineers in our Application Engineering and External Sales functions are available to support you as a development partner worldwide. In order that your machines work more quickly, more reliably and at the same time economically.

Contents

	Page
Technical principles	
Lubrication.....	4
Rolling bearings for textile machinery.....	5
Application examples	26
Appendix	
Addresses.....	54

Technical principles

Lubrication



Lubricants undergo ageing as a result of environmental influences. The information provided by the lubricant manufacturer should be adhered to.

Shelf life of greases

Schaeffler predominantly uses greases with a mineral oil base. Experience shows that these greases can be stored for up to 3 years.

The preconditions for storage are:

- closed room or store
- temperatures between 0 °C and +40 °C
- relative atmospheric humidity not more than 65%
- no contact with chemical agents such as vapours, gases or fluids
- sealed rolling bearings.

After a long period of storage, the start-up frictional torque of greased bearings may temporarily be higher than normal. In addition, the lubricity of the grease may have deteriorated.



The characteristics of greases can vary, even if supplied from a single source.

Rolling bearings for textile machinery

	Page
Product overview	Rolling bearings for textile machinery 6
Features	Spindle neck bearings 7
	Tape tension pulleys and pulley bearings 8
	Tape tension pulleys 8
	Pulley bearings 8
	Application 8
	Thread guidance rollers..... 10
	Speeds 10
	Nip rollers..... 12
	Speed and radial force 12
	Designs..... 12
	Drawn cup needle roller bearings for weaving machines 14
	Particularly small cross-section height 14
	Operating temperature 14
	Cages..... 14
Design and safety guidelines	Spindle neck bearings 7
	Lubrication..... 7
	Tape tension pulleys and pulley bearings 8
	Sealing 9
	Lubrication..... 9
	Thread guidance rollers..... 10
	Lubrication..... 11
	Nip rollers..... 12
	Lubrication..... 13
	Ambient conditions 13
	Drawn cup needle roller bearings for weaving machines 14
	Raceway for bearings without inner ring..... 15
	Static load safety factor..... 15
	Radial location 15
	Installation using fitting mandrel 16
Accuracy	Spindle neck bearings 7
	Drawn cup needle roller bearings for weaving machines 14
	Enveloping circle..... 17
Dimension tables	Spindle neck bearings 19
	Tape tension pulleys 20
	Pulley bearings 21
	Tape tension pulleys and pulley bearings, special designs..... 22
	Nip rollers..... 24
	Bearings for weaving machines, bearings for heald frame drives 25

Product overview Rolling bearings for textile machinery

Spindle neck bearings

With separate end washer, type 1
With double rib, type 2

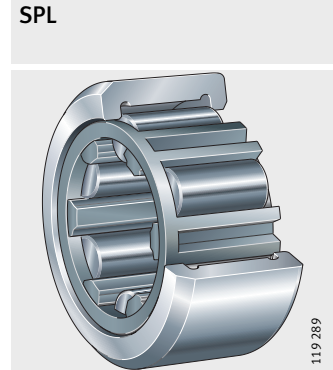
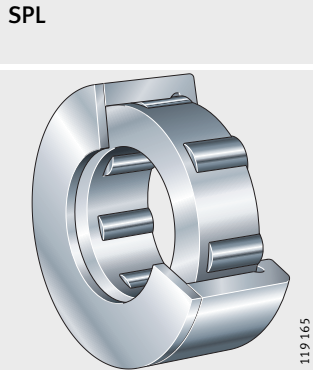

Tape tension pulleys and pulley bearings

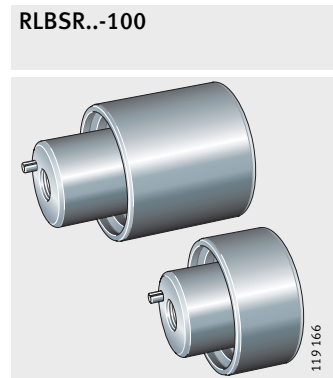

Thread guidance rollers

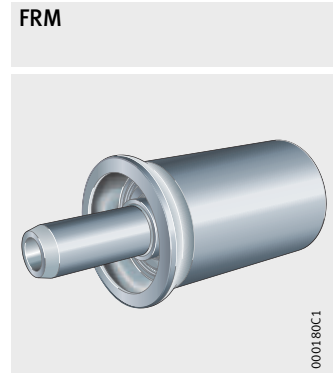
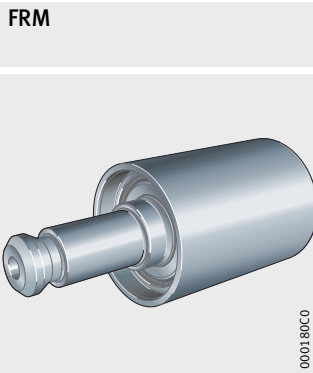

Nip rollers Drawn cup needle roller bearings for weaving machines

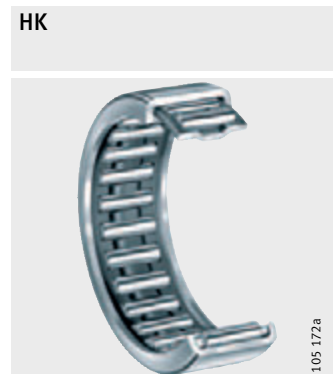
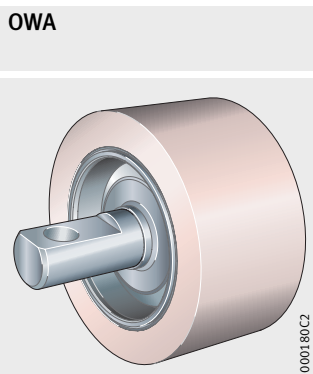

Spindle neck bearings

Features

Spindle neck bearings are cylindrical roller bearings with very high load carrying capacity for the radial guidance of spinning and twisting spindles. They allow high speeds.

The cylindrical rollers in spindle neck bearings are guided by:

- a separate end washer for an inside diameter of 10 mm
- a double rib for an inside diameter of 12 mm.

Design and safety guidelines

Lubrication

Spindle neck bearings are lubricated using oil. Good results have been obtained using oils of ISO-VG10 to ISO-VG46 on the basis of oils CLP to DIN 51517. Spindle neck bearings are supplied coated with a preservative.



If grease lubrication is to be used, consultation with the INA engineering service is required in order to determine the speeds and grease type.

Accuracy

The recommended mounting tolerances are shown in the table.

Mounting tolerances

	Mounting tolerances
Housing	N7
Shaft	j5

Tape tension pulleys and pulley bearings

Features

Tape tension pulleys

Tape tension pulleys BSR are high precision ball bearings with one or two rows of rolling elements. The outer ring half-cups are made from pressed steel. Due to their low mass moment of inertia, the spindles can be rapidly accelerated up to operating speed. Due to the use of gap seals, friction is low.

The pulleys are matched to the normal belt dimensions and mounting conditions.

Pulley bearings

Pulley bearings RLBSR..-100 are high precision ball bearings with one or two rows of rolling elements. Due to their low mass moment of inertia, the spindles can be rapidly accelerated up to operating speed. Due to the use of gap seals, friction is low.

Pulley bearings RLBSR..-100 are also suitable for the design of tape tension pulleys that require special tyres.

Application

Tape tension pulleys are used to guide and tension the drive belts in textile machinery, especially in spinning, texturing and twisting machines.

Design and safety guidelines

Sealing

On the pin side, the pulleys have a gap seal. On the outer side, the pulleys are sealed by a spring diaphragm. The lubrication hole is located at the centre of the diaphragm.

Lubrication

Tape tension pulleys and pulley bearings have an initial greasing of grease K3K-30 to DIN 51825. This grease is a lithium soap grease with a mineral oil base and a base oil viscosity of ISO-VG100.

Relubrication

The grease used for relubrication should be the same as that used for initial greasing. The pulley bearings are relubricated through a lubrication hole in the fixing screw or in the end washer. For this lubrication hole, a metering gun with a tapered nozzle should be used, *Figure 1*.

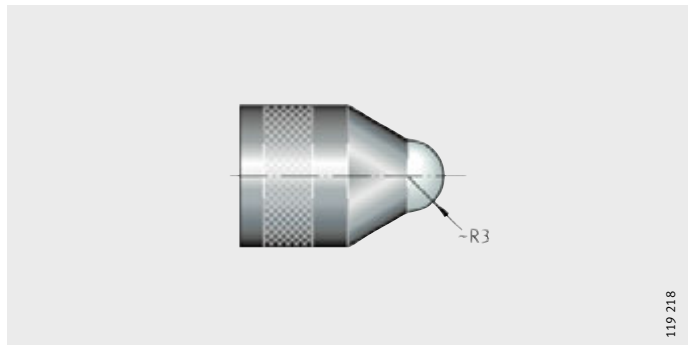

Figure 1
Tapered nozzle

Rotate the bearing by hand in order to ensure uniform distribution of the grease.

The relubrication quantity is as follows:

- 0,5 g to 0,8 g for single row bearings
- 1 g to 1,5 g for double row bearings.

The guide values for the relubrication intervals in operating hours are as follows:

- approx. 30 000 h if little fly is present
- approx. 12 000 h if considerable fly is present.

For information on the shelf life of lubricants, see Technical principles, section Lubrication, page 4.

Thread guidance rollers

Features Thread guidance rollers have an outside surface with hard chromium plating. They run extremely easily and are therefore used in spooling, twisting and texturing machines.

Speeds The maximum permissible speed is as follows:

- 22 500 min⁻¹ for the thread guidance roller F-578204, *Figure 1*
- 22 500 min⁻¹ for the thread guidance roller F-559127.01, *Figure 2*.

F-578204

Figure 1
Thread guidance roller FRM

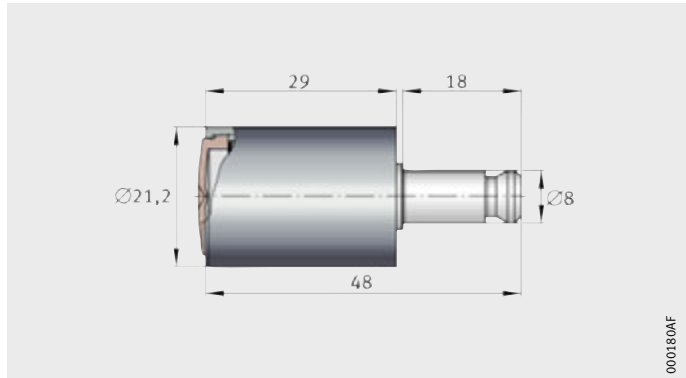

F-559127.01

Figure 2
Thread guidance roller FRM
(separator roller)

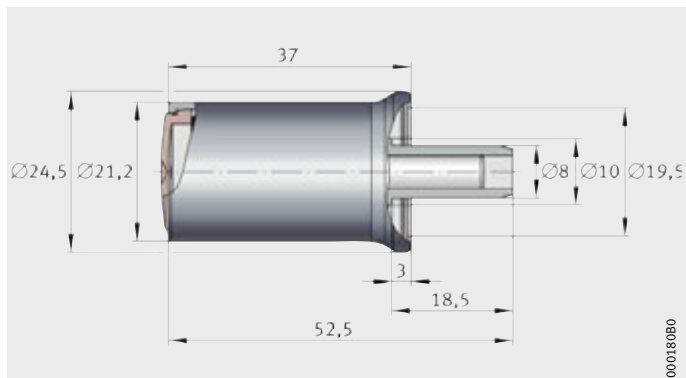

Design and safety guidelines

Lubrication

Thread guidance rollers F-578204, *Figure 1*, page 10, and 559127.01, *Figure 2*, page 10, must be relubricated after operating for 4 000 h.

A conventional syringe is used to press in 0,2 ml of oil to DIN 51502 through the depression in the sealing washer, *Figure 3*.

In order to ensure uniform distribution of the lubricant into the front and rear rows of balls, the thread guidance roller should be placed in a vertical position for approx. 30 minutes. The pin must face downwards.

For information on the shelf life of lubricants, see Technical principles, section Lubrication, page 4.

- ① Syringe
- ② Thread guidance roller
- ③ Position for lubricant distribution

Figure 3
Relubrication
of thread guidance rollers

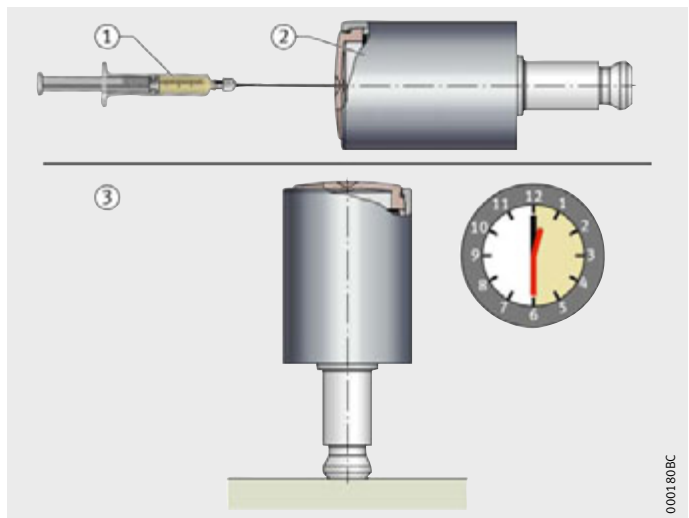

Nip rollers

Features Nip rollers OWA are units comprising these elements: covering, deep drawn sleeve, deep groove ball bearing, pin and integrated tilt mechanism. The nip roller can tilt in precisely one plane. This mechanism compensates misalignments and allows precise running of the synthetic fibres.

Speed and radial force The maximum permissible draw-off speed is 1 500 m/min. This gives an operating speed of 7 350 min⁻¹ if the covering has an outside diameter of 65 mm and 9 000 min⁻¹ for 53 mm. The permissible radial force F_r is 100 N.

Designs Nip rollers OWA are supplied with or without a covering, *Figure 1* and *Figure 2*. As standard, coverings DB372 and S880-Alu are available. Other coverings are available by agreement from various manufacturers in different sizes.

OWA F-575102
OWA F-575102.01

Figure 1
Nip roller OWA with covering

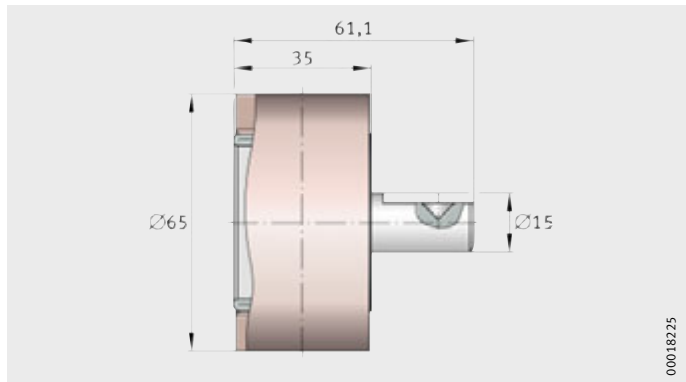

OWA F-575102-100

Figure 2
Nip roller OWA without covering

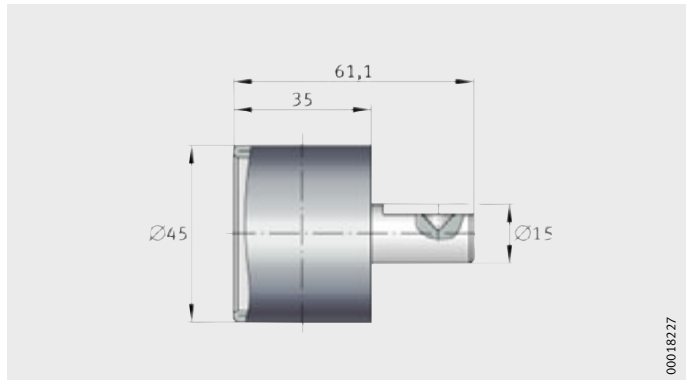

Design and safety guidelines

Lubrication

Nip rollers OWA have an initial greasing of grease to Grease Specification 0013. The nip rollers must be relubricated after 7 000 h.

Ambient conditions

Nip rollers are suitable for use at a humidity between 45% and 65%. The ambient temperature should not exceed +50 °C; in continuous operation, a maximum temperature of +70 °C is permissible.

For information on the shelf life of lubricants, see Technical principles, section Lubrication, page 4.

Drawn cup needle roller bearings for weaving machines

Features Drawn cup needle roller bearings are complete units comprising thin-walled, drawn cup outer rings and needle roller and cage assemblies. They conform to DIN 618-1 or ISO 3245 and are available for shafts from 40 mm to 70 mm.
Drawn cup needle roller bearings HK are not sealed on either side.

Particularly small cross-section height Due to the thin-walled outer cup and the design without an inner ring, drawn cup needle roller bearings have extremely small radial dimensions. They have high load carrying capacity, are suitable for high speeds and are particularly easy to fit. If shoulders, snap rings etc. are not used for axial location, the housing bore can be produced easily and particularly economically.
Drawn cup needle roller bearings require a bearing raceway on the shaft that is hardened and ground. If the shaft cannot be used as a raceway, they can be combined with inner rings IR or LR. For suitable inner rings, see Catalogue HR 1, Rolling Bearings.

Operating temperature Drawn cup needle roller bearings without seals can be used at operating temperatures up to +140 °C.

Cages Drawn cup needle roller bearings for weaving machines have sheet steel cages.

Design and safety guidelines for bearings without inner ring

Raceway

In the case of bearings without an inner ring, the rolling element raceway on the shaft must be hardened and ground. The raceway must have a surface hardness of at least 670 HV, the hardening depth CHD or Rht must be sufficiently large.

For information on design of the shaft and housing, see table and the chapter Design of bearing arrangements, Catalogue HR 1, Rolling Bearings.



In order to utilise the load carrying capacity of the bearings to the full, rigid support must be provided for the thin-walled outer ring. Observe the recommended bore tolerance in accordance with table.

Tolerances for shaft raceway and housing bore

Housing material	Shaft tolerance for bearings without inner ring	Bore tolerance
Steel or cast iron	h6	N6
Light metal Al		R6
Mg		S6

Surface for shaft raceway and housing bore

Surface quality	Shaft raceway for bearings without inner ring	Housing bore
Roughness max.	Ra0,2 (Rz1)	Ra0,8 (Rz4)
Roundness	IT 3	IT 5/2
Parallelism	IT 3	IT 5/2

Static load safety factor

$$S_0 = \frac{C_{0r}}{P_0}$$

S_0 – Static load safety factor
 C_{0r} – N Basic static load rating according to dimension tables
 P_0 – N Equivalent static bearing load.



In order to achieve sufficiently smooth running, a static load safety factor $S_0 \geq 3$ is necessary.

Radial location

Drawn cup needle roller bearings are pressed into the housing bore and require no further axial location.

Drawn cup needle roller bearings for weaving machines

Installation with fitting mandrel

The bearings should be installed using a special fitting mandrel, *Figure 1*. The fitting mandrel shoulder should rest on the bearing end face marked with the designation.

A toroidal ring ① should be used to retain the bearing. The length and oversize of the toroidal ring must be matched by the customer to the dimensions and mass of the bearing.

Before installation, the bearings should be lubricated with grease, if grease lubrication is to be used.



Bearings should not be tilted during fitting.

Forces occurring during the fitting process are dependent on several variables. The fitting situation should be arranged so that the bearing rib on the end face is not deformed.

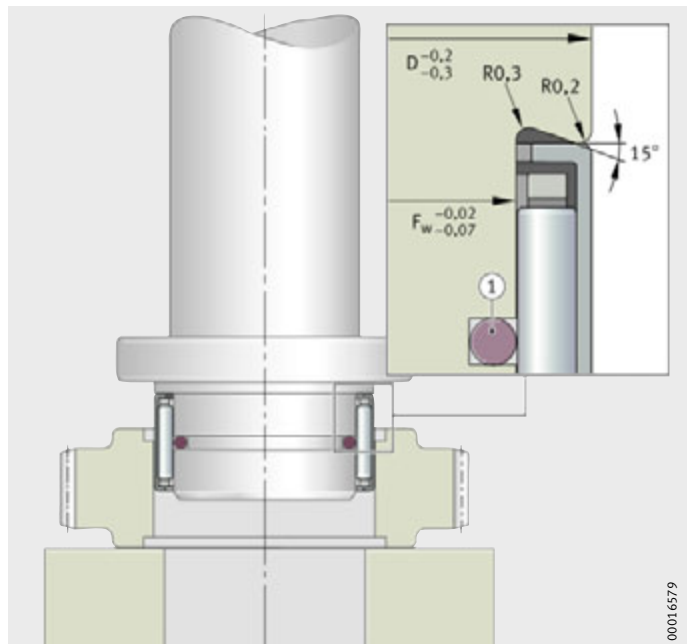

① Toroidal ring

Figure 1
Installation using a fitting mandrel

Accuracy

The main dimensions of the bearings conform to DIN 618 and ISO 3245.

The thin-walled outer rings adopt the dimensional and geometrical accuracy of the housing bore.

Enveloping circle

In the case of bearings without an inner ring, the dimension for the enveloping circle F_w is used instead of the radial internal clearance.

The enveloping circle is the inner inscribed circle of the needle rollers in clearance-free contact with the outer raceway.

Once the bearings are fitted, the enveloping circle F_w is approximately in tolerance zone F8 (assuming bore tolerances according to table Tolerances for shaft raceway and housing bore, page 15).

The enveloping circle is determined on the basis of the inspection dimensions in accordance with the table.



Bearings used for enveloping circle measurements should not be repeatedly pushed in and out of the gauge. Bearings which have been checked in the ring gauge should not be used again.

Inspection dimensions for drawn cup needle roller bearings

Enveloping circle diameter F_w mm	Bearing outside diameter D mm	Ring gauge bore Actual dimension mm	Enveloping circle diameter	
			Upper deviation μm	Lower deviation μm
40	47	46,972	+50	+25
45	52	51,967	+50	+25
50	58	57,967	+50	+25
55	63	62,967	+60	+30
60	68	67,967	+60	+30
70	78	77,967	+60	+30

Spindle neck bearings

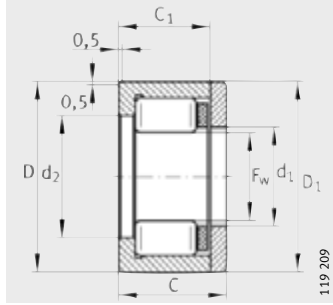

SPL
Type 1

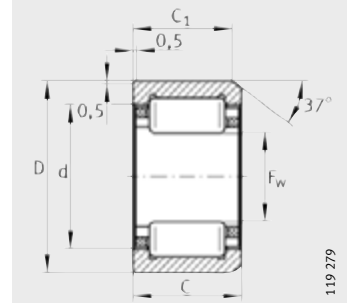

SPL
Type 2

Dimension table - Dimensions in mm

Designation	De- sign	Mass m ≈ g	Dimensions							Basic load ratings		Limiting speed ¹⁾ n _G min ⁻¹
			F _w	D	D ₁	C	d ₁	d ₂	C ₁	dyn. C N	stat. C ₀ N	
SPL10.22	2	13,5	10	22	–	11,3	–	16,3	10,2	7 100	5 300	35 000
SPL12.24	1	19,5	12	24	23,95	11	12,7	17	10	6 500	4 800	33 000

¹⁾ Limiting speed for oil lubrication.

Tape tension pulleys

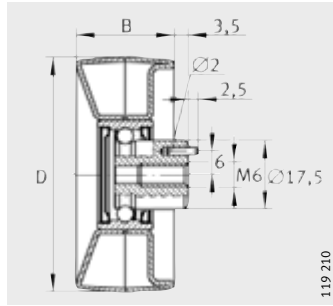

BSR61

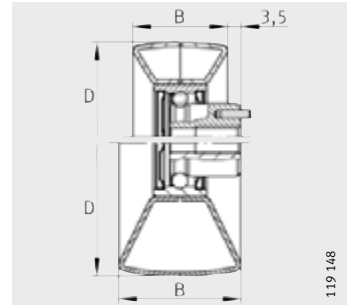

BSR51, BSR71
BSR72

Dimension table · Dimensions in mm

Designation	Mass m ≈g	Dimensions		Limiting speed ¹⁾
		D	B	n _G min ⁻¹
BSR51	133	50	25	8 000
BSR61	133	60	25	8 000
BSR71	155	70	25	8 000
BSR72	170	70	32	8 000
BSR720	203	70	32	15 000
BSR73	241	70	45	15 000

¹⁾ Limiting speed for grease lubrication.

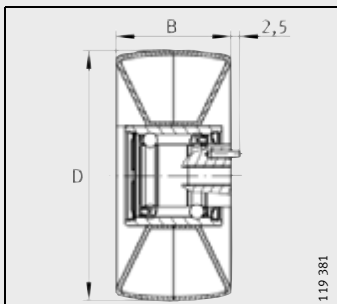

BSR720

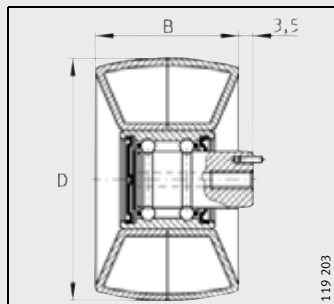

BSR73

Pulley bearings

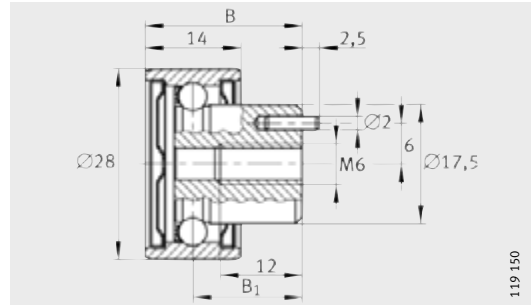

RLBSR71-100

Dimension table - Dimensions in mm

Designation	Mass m ≈g	Dimensions		Basic load ratings		Limiting speed ¹⁾ n _G min ⁻¹
		B	B ₁	dyn. C N	stat. C ₀ N	
RLBSR71-100	55	23	16	4 050	1 980	8 000
RLBSR73-100	104	39,5	26	6 200	3 950	15 000

¹⁾ Limiting speed for grease lubrication.

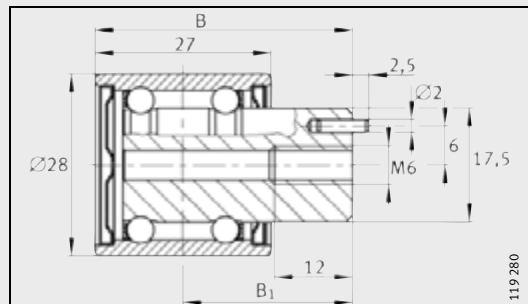

RLBSR73-100

Tape tension pulleys and pulley bearings

Special designs

Dimension table · Dimensions in mm

Designation	Mass m ≈g	Dimension D	Belt width	Basic load ratings		Limiting speed ¹⁾ n _G min ⁻¹
				dyn. C N	stat. C ₀ N	
F-80491	55	28	14	4 050	1 980	8 000
F-56202	84	42	30	4 050	1 980	8 000
F-50230	202	50	30	6 200	3 950	15 000
F-56618	167	50	21	6 200	3 950	15 000
F-238287	330	50	26	14 800	9 600	8 000
F-207228	500	69	28	8 800	6 600	11 000
F-211420	560	69	42	8 800	6 600	11 000

¹⁾ Limiting speed for grease lubrication.

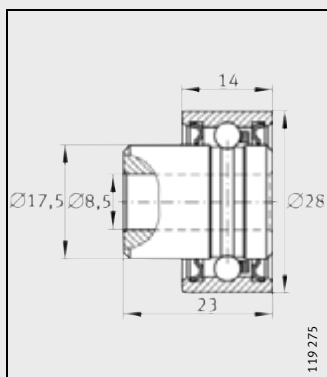

F-80491

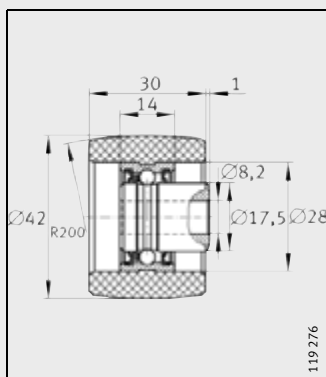

F-56202

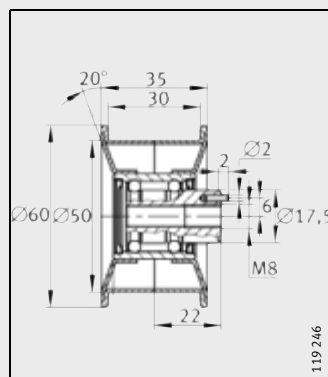

F-50230

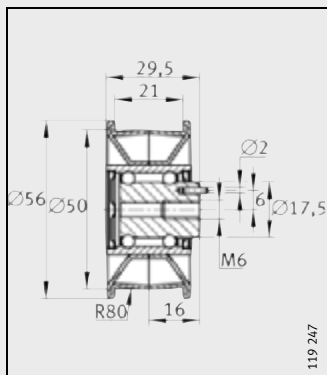

F-56618

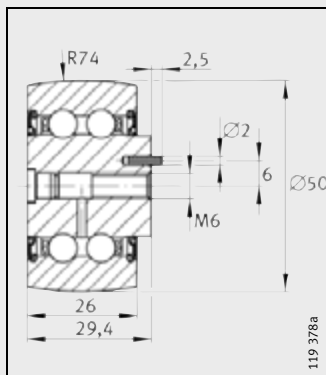

F-238287

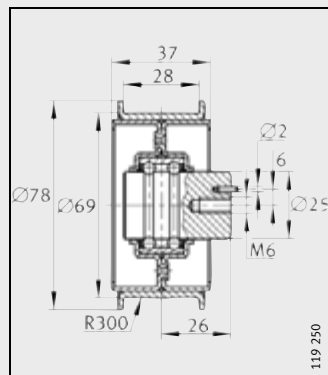

F-207228

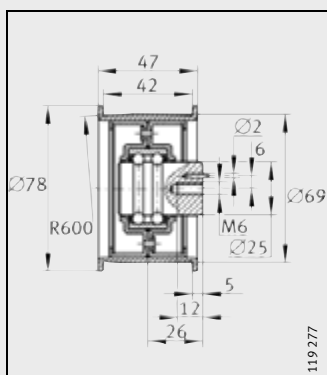

F-211420

Nip rollers

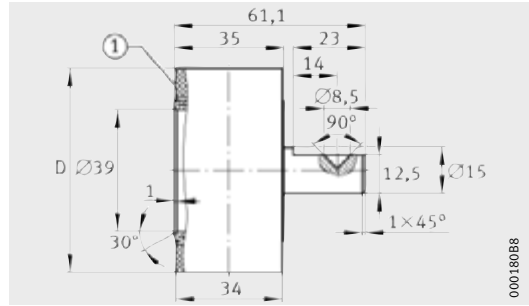

F-575102, F-575102.01

000180B8

Dimension table · Dimensions in mm

Designation	Mass m ≈g	Dimensions		Covering ¹⁾	Basic load ratings	
		D	D ₁		dyn. C N	stat. C ₀ N
OWA F-575102	308	65	–	DB372	9 400	5 000
OWA F-575102.01	308	65	–	S880-Alu	9 400	5 000
OWA F-575102-100	210	–	45	–	9 400	5 000

¹⁾ Note!

Other coverings are available by agreement from various manufacturers in different sizes.

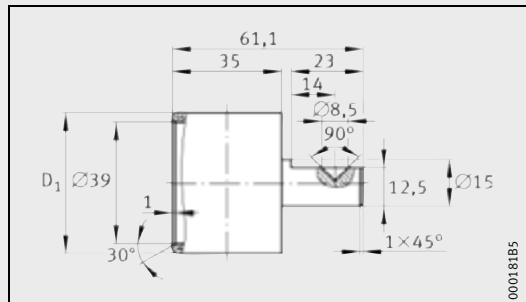

OWA F-575102-100

000181B5

Bearings for weaving machines

Bearings for heald frame drives

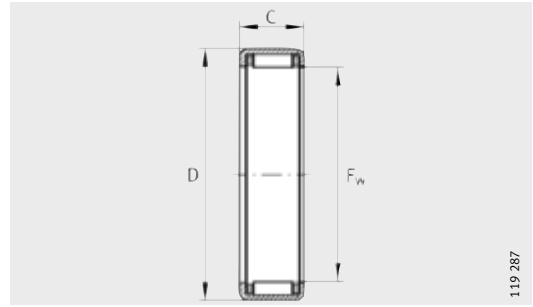

HK

119 287

Dimension table - Dimensions in mm

Designation	Mass m ≈g	Dimensions			Basic load ratings	
		F _w	D	C	dyn. C N	stat. C ₀ N
HK4012	30	40	47	12	14 000	24 300
HK4512	33	45	52	12	14 900	27 500
F-33412	45	50	58	12	16 900	29 900
HK6012	49	60	68	12	17 400	32 000
F-229134	69	70	78	12	19 900	40 000

For other sizes, see Catalogue HR 1, Rolling Bearings.

Application examples

	Page
Fibre processing in a carding machine	Requirements 28
	Design solution 29
	Schaeffler Group products used 29
Flyer	Requirements 30
	Design solution 31
	Schaeffler Group products used 31
Rotor spinning machine	Requirements 32
	Design solution 32
	Schaeffler Group products used 33
Spinning line	Requirements 34
	Design solution 35
	Schaeffler Group products used 35
Production of synthetic fibres	Requirements 36
	Design solution 37
	Schaeffler Group products used 37
Chuck shaft	Requirements 38
	Design solution 39
	Schaeffler Group products used 39

	Page
Texturing machine	
Requirements	40
Design solution.....	41
Schaeffler Group products used	42
Weaving machine	
Rapier drive	
Requirements	44
Design solution.....	45
Schaeffler Group products used	45
Lay drive	
Requirements	46
Design solution.....	47
Schaeffler Group products used	47
Weaving machine	
Requirements	48
Heald frame drive bearing	
arrangements	
Requirements	49
Design solution.....	49
Schaeffler Group products used	49
Needle felting machine	
Requirements	50
Design solution.....	50
Schaeffler Group products used	51
Dryer rolls	
Requirements	52
Design solution.....	53
Schaeffler Group products used	53

Fibre processing in a carding machine

Fibres that are still disordered are processed in high performance revolving flat cards to form a strip for drafting arrangements or direct spinning machines. Such cards lay the disordered cotton and synthetic fibres parallel to each other. Fibres that are too short are separated out and contaminant particles are removed.

The card is fed with fibres of differing origin and various materials. Several million card clothing points on the roll known as a carding cylinder separate the disordered fibres and lay them parallel.

A further roll, the stripper roll, also has several million card teeth. The stripper roll rotates more slowly than the carding cylinder.

As a result, the stripper roll draws the fibres off the carding cylinder as nonwoven tissue.

Pinch rolls transport the nonwoven tissue uniformly onward and guide it to the funnel. Calender rolls ensure compaction of the strip so that it can be deposited in an ordered manner in the can. In the can, the strip is conveyed for further processing.



Figure 1

High performance revolving flat card

Requirements

A carding cylinder with card points runs at a circumferential speed of approx. 26 m/s. The nonwoven tissue must be guided at this speed over the stripper rolls, pinch rolls and calender rolls into the can.

The calender rolls run at a speed of up to 2 000 min⁻¹.

The requirement is for maintenance-free running for 40 000 h. In spite of this requirement, the bearing arrangement must run smoothly and precisely.

Design solution

The Schaeffler Group has developed an optimised roll bearing arrangement for this task. It achieves the required values and is a compact unit.

The calender roll comprises a double row ball bearing arrangement in which the balls run directly on the shaft of the bearing arrangement. The roll is pushed onto the shaft of the compact unit. The roll is clamped on one side using a locking collar. The gear on the opposite side to the drive is located by means of a feather key and screw.

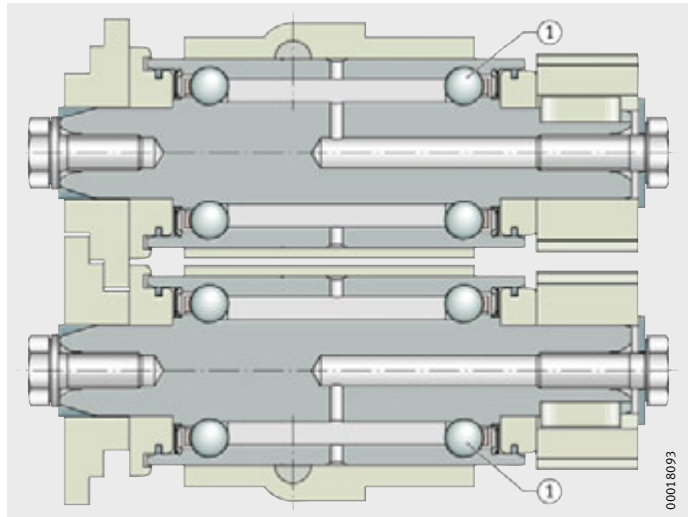

① Special ball bearing LWTX

Figure 2
Roll bearing arrangement

Schaeffler Group products used

① Special ball bearing LWTX.

Flyer

High quality roving makes a major contribution to the problem-free running of ring spinning machines. A flyer is therefore used to process a uniform sliver to produce roving with the necessary characteristics, *Figure 1*.

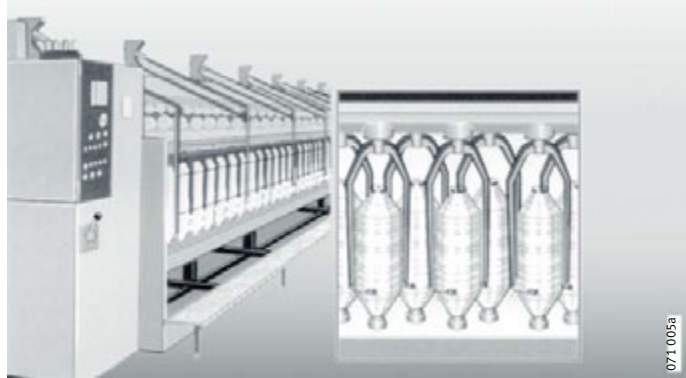

Figure 1
Flyer

Requirements

The drafting arrangement and flyer are principal components of the flyer spinning frame. As a first step, the sliver is stretched. Then the flyer twists the sliver to produce roving for the ring spinning machine. The flyer spinning frame rotates at approx. 1800 min^{-1} .

The bearings are subjected to high centrifugal forces but must nevertheless run smoothly and accurately. It is only in this way that roving of sufficiently high quality can be produced.

Design solution

The Schaeffler Group special ball bearing, containing ball and cage assemblies at a relatively large distance from each other, must support high forces. Furthermore, the operating clearance of the bearing has been restricted. These measures ensure smooth running and thus high quality roving.

The ball bearing is lubricated for life and has highly effective sealing against dust and fly. Since the complete bearing arrangement of the flyer consists of this one bearing only, it is easy to fit.

① Special ball bearing KLB

Figure 2
Flyer bearing arrangement

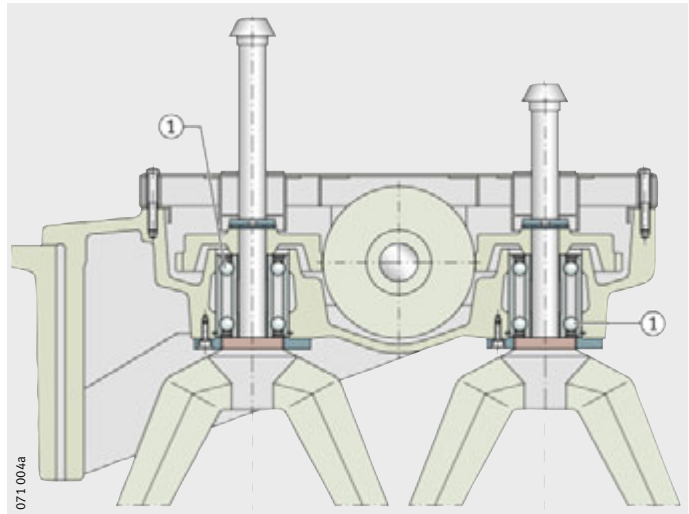

① Special ball bearing KLB

Figure 3
Detail: Flyer bearing arrangement

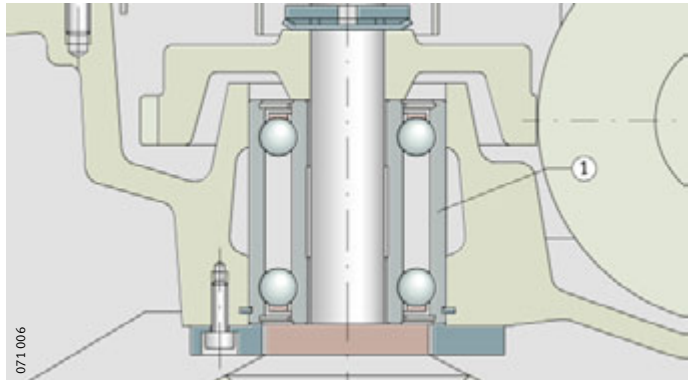

Schaeffler Group products used

① Special ball bearing KLB.

Rotor spinning machine

Turning fibres into yarn: rotor spinning is a particularly effective technique for this task. The opening roller separates the fibres which are then transported to the rotor. The rotor twists the fibres about each other, producing the yarn.

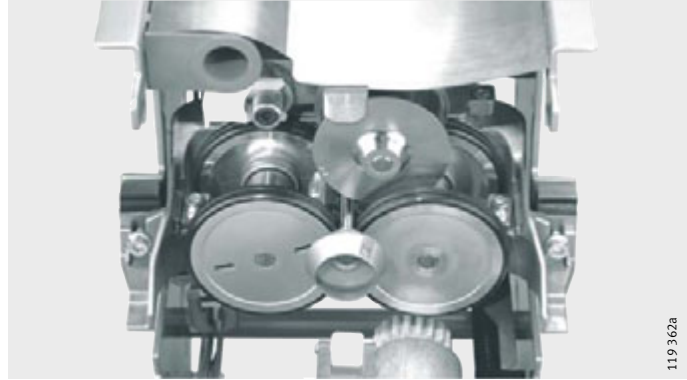

Figure 1
Rotor spinning machine

Requirements

The rotor is driven by a flat belt. A tape tension pulley presses the belt against the rotor shaft. The shaft is supported on four large pulleys in the indirect rotor bearing arrangement. The speeds are high: $150\,000\text{ min}^{-1}$ at the rotor, $15\,000\text{ min}^{-1}$ to $21\,000\text{ min}^{-1}$ at the bearings and rolls.

At these high speeds, small masses and low-friction running are essential. Vibrations will impair the quality of the yarn produced, so the bearings and rollers must run smoothly.

Design solution

The opening roller and wharve are pressed onto a double row special ball bearing. The restricted axial and radial internal clearance give smooth, quiet running. Due to the large spacing between the two rows of balls, the bearing in the opening cylinder can support high loads. It is reliably protected against fibres by two sheet metal seals.

A double row special ball bearing is also fitted in the Schaeffler Group tape tension pulley. The pulley is pressed onto the shaft. In order to ensure quiet running of the tape tension pulley at $21\,000\text{ min}^{-1}$, it is dynamically balanced.

The special ball bearing in the indirect rotor bearing arrangement has protruding shaft ends on both sides. The support pulleys are pressed onto these ends. The radial runout must be close to zero once they are pressed on. In this case, extremely smooth running of the rotor is ensured.

① Special ball bearing LWTX

Figure 2
Special ball bearing LWTX
for opening roller

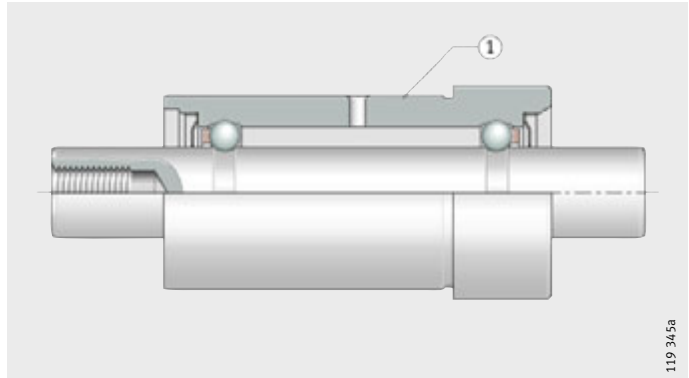

② Tape tension pulley BSR

Figure 3
Tape tension pulley BSR
in the rotor drive

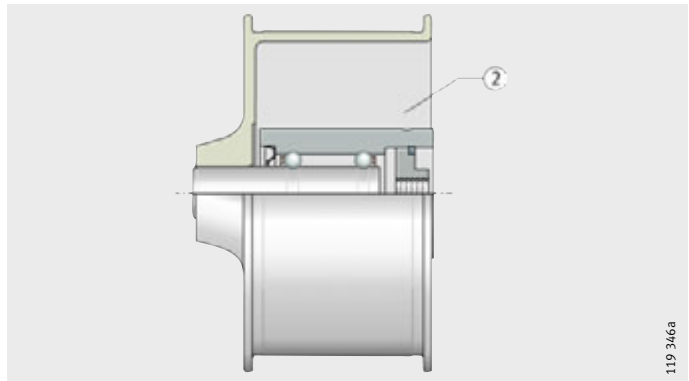

③ Indirect rotor bearing arrangement RTL

Figure 4
Indirect rotor bearing arrangement
RTL

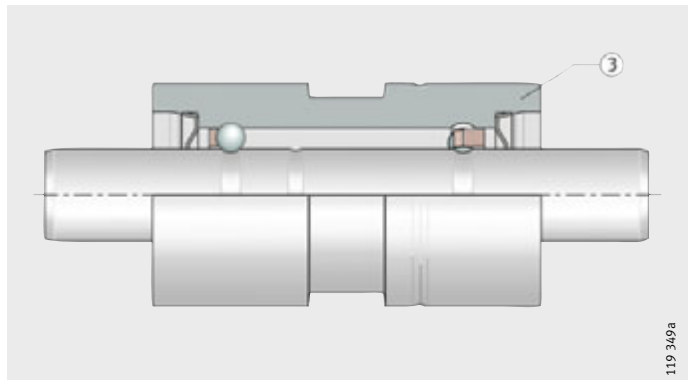

**Schaeffler Group
products used**

- ① Special ball bearing LWTX for opening roller
- ② Tape tension pulley BSR in the rotor drive
- ③ Indirect rotor bearing arrangement RTL.

Spinning line

Mountain climbers, hikers, runners and even walkers – everyone is now looking for practical clothing. Light yet robust, waterproof but breathable, clothing made from contemporary materials has displaced cotton, leather and other time-honoured materials.

Such clothing is woven from fully drawn, synthetic filament yarns. These yarns are produced on spinning and drawing lines. These lines carry out numerous process operations: they begin with granulate feed and progress through melting and homogenising of the polymer melt. The further steps are spinning and drawing, after which the winders spool the yarn.

Drawing of the yarn ensures high strength and good mechanical characteristics. Once the polymer chains are spun, they are present in a disordered state in the unstretched filament and their strength is not adequate for direct further processing.



Figure 1
Spinning and drawing line

Requirements

The spun yarns are guided via several godets. Since the following godet always rotates more quickly than the previous one, the yarns are drawn to a multiple of their original length. The molecular chains are aligned to the axis of the fibres and the mechanical characteristics of the fibres are realised. The extent to which the threads are stretched can be adjusted by the ratio of the godet speeds to each other.

High speeds are required in the godet bearing arrangement together with smooth and uniform running. This has a direct effect on the quality of the drawn yarns. Furthermore, the bearing arrangement must withstand different temperatures since the godets run cold or hot depending on the filament.

Design solution

The godet shaft rotates in two deep groove ball bearings. These bearings are fitted in an X arrangement and are preloaded. The design gives high precision guidance of the godet shaft and prevents vibrations. In this way, it is ensured that the stretched yarn is of the required quality. If the godets run hot, the bearing arrangement must be matched to the higher operating temperatures. The bearing components undergo heat treatment and a high temperature grease is used.

A spring preload system ensures optimum contact between the rolling elements and raceways under all operating conditions. It also allows length compensation at the non-locating bearing, which is mounted with a push fit on the outer ring.

The bearings are sealed and greased for life with a high temperature grease.

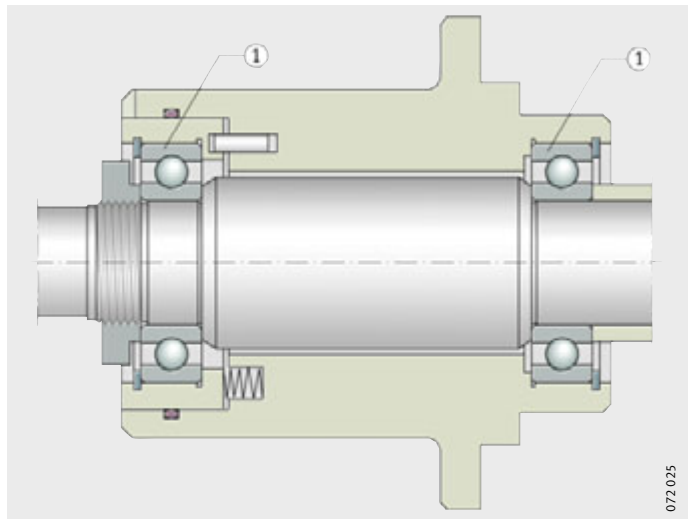

① Deep groove ball bearing
6013-2ZR-C4-L237

Figure 2
Godet
with deep groove ball bearings

Schaeffler Group products used

① Deep groove ball bearing 6013-2ZR-C4-L237.

Production of synthetic fibres

The dimensions of the production line for producing synthetic fibres from a polymer melt are enormous: over a length of 100 m, synthetic staple fibres are produced, from the spinning stage to the packed fibre.

The significant process operations are spinning, stretching, thermofixing, crimping, cutting and pressing. On its passage along the line, the melt is transformed into a fibre in textile form. This fibre can then be spun either alone or mixed with natural fibres.

Once the melt has been spun through very fine nozzles into filaments, several of these thin filaments are gathered into one yarn. Several such yarns give a fibre cable.

The cables produced in this way must then be refined. This means above all that they must have sufficient strength before they can be processed in the textile industry.

The first refining station on the fibre line is the drafting arrangement. The fibre cables are drawn between heatable drafting rolls. The molecular structure of the filaments is aligned in this way and the fibres acquire the necessary strength.



Figure 1
Production of synthetic fibres

Requirements

The fibre cable must be laid easily and quickly on the drafting roll, the so-called godet. Misalignments occur at the bearing position. The godet is deflected as a result of the drive force, drafting force and weight. The roll heats up during operation, making length compensation necessary in the bearing arrangement.

Operating data

Operating data		
Speed	min ⁻¹	100 to 200
Temperature	°C	90

Design solution

The godets are supported in a floating arrangement which simplifies usability when laying the cable. Spherical roller bearings are selected since they are able to compensate misalignments. Spherical roller bearings also support the high forces that occur during drafting. In order to prevent the occurrence of stresses due to elongation at higher temperatures, the bearing arrangement comprises a locating bearing and a non-locating bearing. The non-locating bearing compensates the elongation.

- ① Spherical roller bearing with cylindrical bore 23176-MB-C3
- ② Spherical roller bearing with tapered bore 23188-K-MB-C3
- ③ Withdrawal sleeve for hydraulic mounting AHX3188-H

Figure 2
Godet bearing arrangement

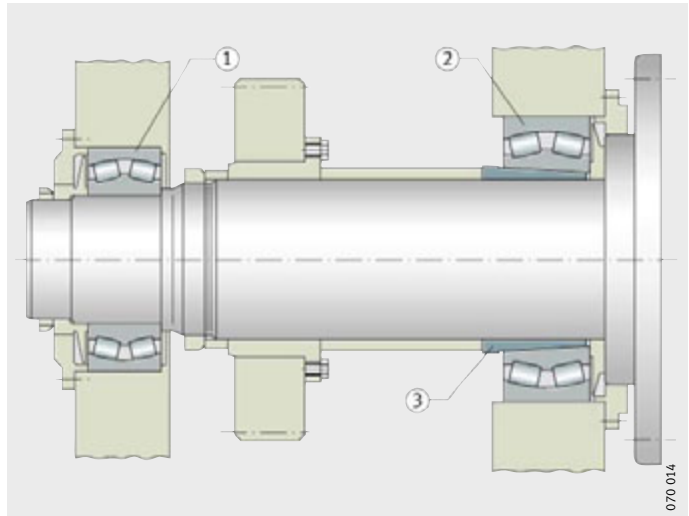

Schaeffler Group products used

- ① Spherical roller bearing with cylindrical bore 23176-MB-C3
- ② Spherical roller bearing with tapered bore 23188-K-MB-C3
- ③ Withdrawal sleeve for hydraulic mounting AHX3188-H.

Chuck shaft

Clothing made from synthetic fibres, which is robust and waterproof yet breathable, has displaced time-honoured materials. The machines for synthetic fibre production are therefore increasing in importance compared to machines working with natural fibres. For synthetic fibre production, the Schaeffler Group has developed a new chuck shaft for spooling up of filaments.

In the Schaeffler Group, the chuck shaft has been calculated using the rotor dynamics module of the rolling bearing calculation software BEARINX[®]. The module was programmed in the development department of the Schaeffler Group. It is designed for the high requirements of chuck shafts.

- ① Filaments
- ② Chuck rotates, filaments are spooled up
- ③ Chuck is stationary, finished filament spools

Figure 1
Winding principle

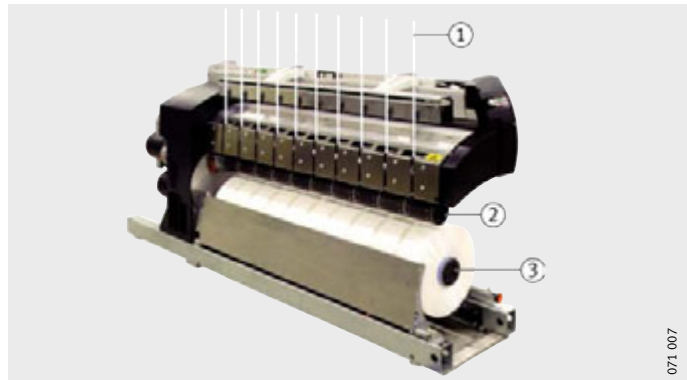

Requirements

The chuck shaft rotates at approx. $15\,000\text{ min}^{-1}$ and has a rotor system with considerable masses. These operating data conceal the risk of resonance vibrations during operation. The vibration behaviour of the chuck shaft must therefore be precisely investigated.

High running accuracy, under which the shaft may only undergo radial wobble of a few micrometres, is a precondition for spooling with very high quality at high delivery speed. The vibration amplitude for the chuck shaft must be as small as possible. Orthotropic rigidity and damping in the bearings must also be taken into consideration in development, together with the damping elements, the gyroscopic effect and all six degrees of freedom in the motion formula.

Design solution

The chuck shaft is supplied as a ready-to-fit unit and mounting is therefore very simple and quick. The double row ball bearings preloaded free from clearance on the chuck shaft were designed for a rating life of more than 50 000 h.

During development, investigations were carried out into natural frequencies, critical speeds and the effect of imbalance excitation at defined measurement points.

The rotor dynamics module in the rolling bearing calculation software BEARINX[®] helps to reduce the number of test series. This reduces the development costs and allows cost-effective solutions.

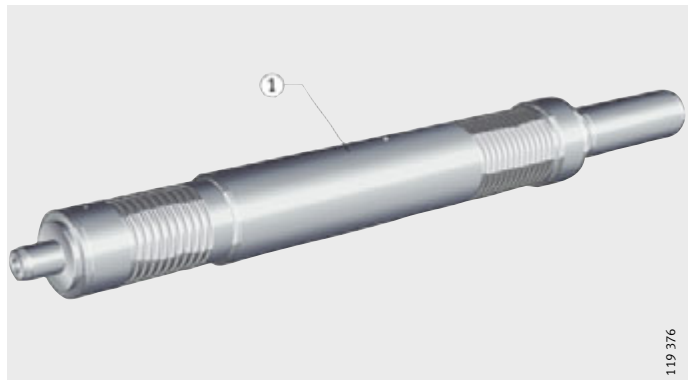

① Special ball bearing LWTX

Figure 2
Chuck shaft

Schaeffler Group products used

① Special ball bearing LWTX.

Texturing machine

Going back just a few decades: textiles made from synthetic fibres were “sticky” and not at all pleasant to wear – even if the advertising claimed otherwise. This has changed fundamentally. Synthetic fibres have completely lost their sticky charm and this is due in part to texturing machines that give the fibres and thus the textiles some of their comfortable characteristics.

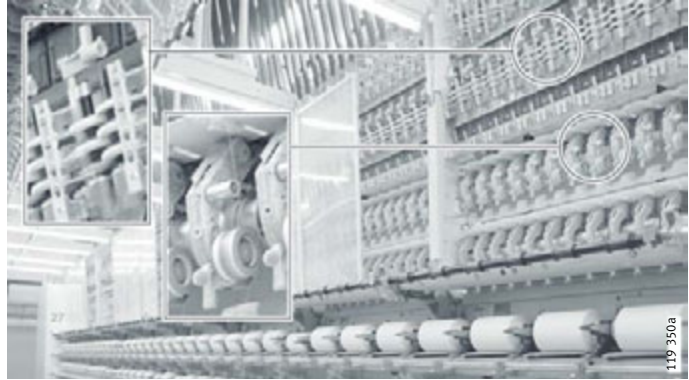

Figure 1
Texturing machine

Requirements

Texturing machines give the plain, untreated filament a crimped effect. The filament has a speed of up to 1 500 m/min, the spindle speed can reach 25 000 min⁻¹. Nip rollers and thread guidance rollers guide the filament through the texturing machine.

Smooth, quiet running without vibrations is essential in the texturing machine.

Operating data

Product	Speed min ⁻¹
Friction spindle	25 000
Nip roller	7 350
Thread guidance roller	22 500

Design solution

In the friction spindle, the upper bearing is suspended “elastically”. The friction spindle therefore runs uniformly and quietly even at $8\,000\text{ min}^{-1}$ to $25\,000\text{ min}^{-1}$.

The nip roller is a special bearing with a tilting mechanism for the pin. This mechanism allows the roller to tilt in precisely one plane. Misalignment can thus be compensated. If the nip roller tilted in more than one plane, thread running would become imprecise. The nip roller is lightweight and can accelerate quickly when it contacts the delivery shaft.

For the thread guidance roller, the Schaeffler Group supplies a special ball bearing with a hard chromium surface plating. The pulley on the roller is produced by deep drawing. Due to this structure, bearing geometry and the lubrication method, the roller has a very low starting torque and can accelerate very easily.

All the components supplied by the Schaeffler Group, such as rollers or spindles, have effective protection against dust and the ingress of fibres that are generated in textile processing.

① Friction bearing FDS

Figure 2
Friction bearing FDS



② Nip roller OWA

Figure 3
Nip roller OWA

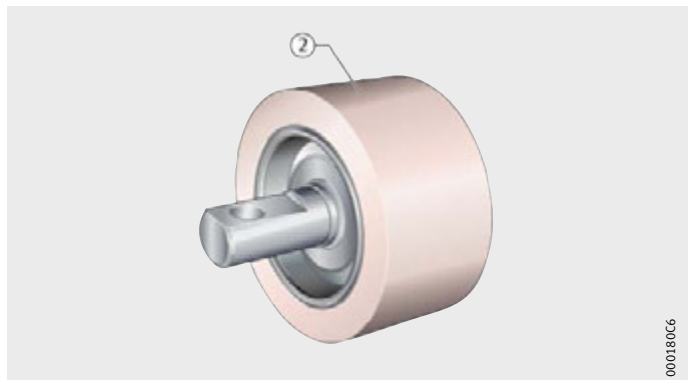

Texturing machine

③ Thread guidance roller FRM

Figure 4
Thread guidance roller FRM

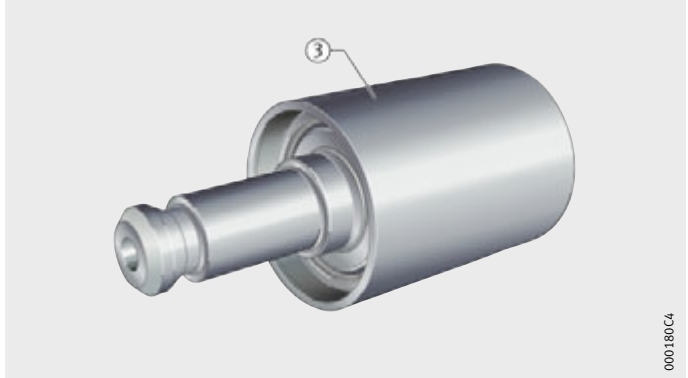

③ Thread guidance roller FRM

Figure 5
Thread guidance roller FRM

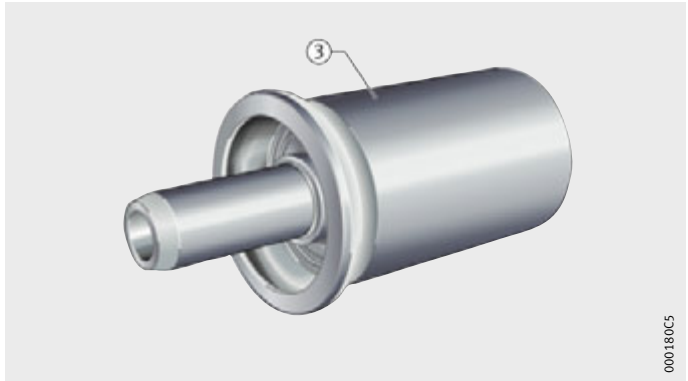

Schaeffler Group products used

- ① Friction bearing FDS
- ② Nip roller OWA
- ③ Thread guidance roller FRM.

Weaving machine Rapier drive

Rapier weaving machines produce a wide range of materials: light materials that ideally will remain hidden in the airbag, to heavy materials such as terry towelling that are pleasant against the skin.

Two rapiers, one on each side, guide the thread through the shed. Each rapier must shoot in and out of the shed approx. 600 times a minute. In the middle, the carrying rapier passes the thread to the drawing rapier.

Each rapier is driven back and forth by an elastic tape via an oscillating pulley. In order to prevent the elastic rapier tape lifting off the pulley, the rapier tape is pressed against the pulley by a continuous belt. The continuous belt is guided on two tape tension pulleys.

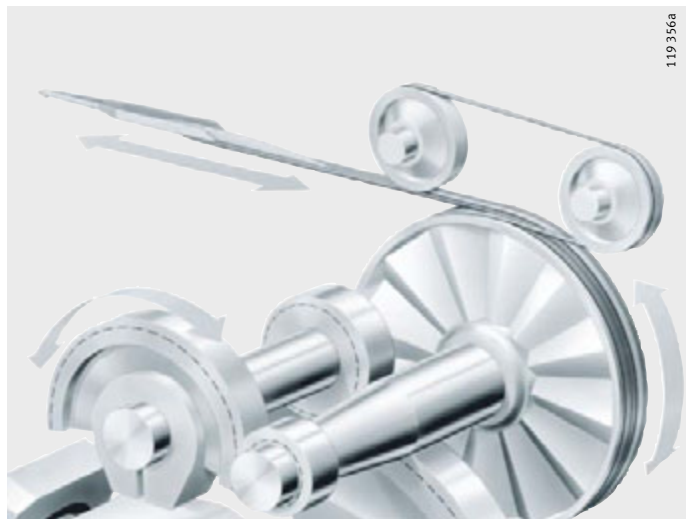

Figure 1
Rapier weaving machine

Requirements

These tape tension pulleys must have particularly low mass, since they undergo acceleration and braking approx. 600 times a minute. This results in continual reverse bending load on the bearing cage in the tape tension pulley.

Design solution

The Schaeffler Group has fulfilled this requirement using very light tape tension pulleys comprising a ball bearing and a plastic pulley. The Schaeffler Group design and the special injection moulding process ensure permanent seating of the pulley on the bearing. This applies to both radial and axial loads.

Due to its design, the tape tension pulley is very light. It can therefore be easily reversed and requires little energy.

The tape tension pulley is sealed by the adjacent construction. The pulley can be relubricated via a hole in the inner ring.

The running surface of the pulley has a slightly curved profile, so the continuous belt is pushed consistently towards the centre of the running surface and is thus guided securely.

① Tape tension pulley BSR

Figure 2
Tape tension pulley
in the rapier drive

**Schaeffler Group
products used**

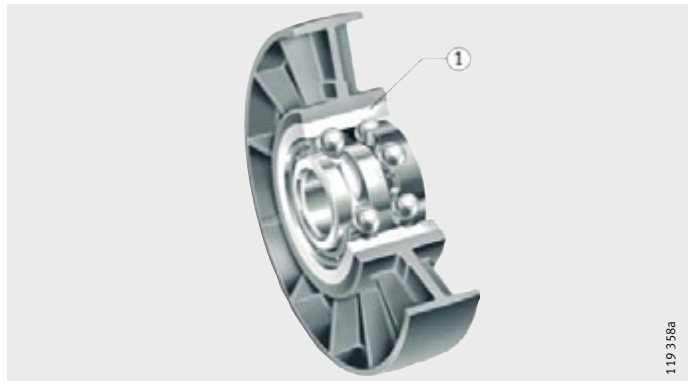

① Tape tension pulley BSR.

Weaving machine

Lay drive

The lay beats the weft thread which has been inserted between the warp threads. This process keeps the woven material tight and completes each entry of the weft. To beat the weft thread, the lay is moved to the edge of the material and then returned to its original position. The lay is driven by a double eccentric.

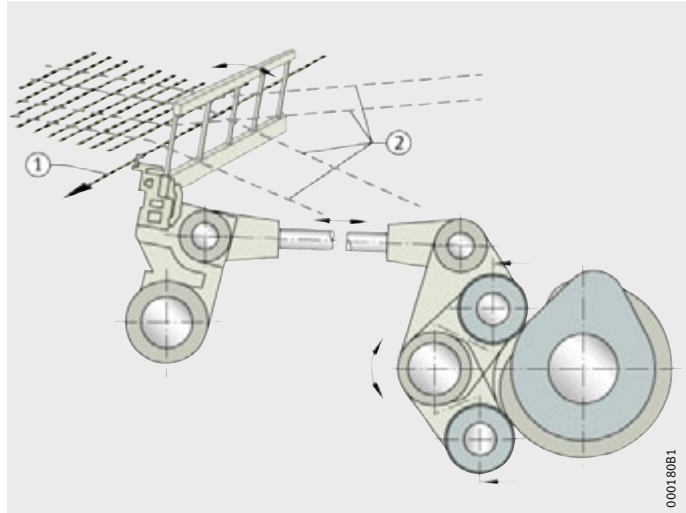

- ① Weft thread
- ② Warp threads

Figure 1
Lay drive

Requirements

Track rollers on a double lever run on both cams on the eccentric. The lever converts the rotation of the cams into an oscillating movement.

The high shock loads and the subsequent reversed bending stresses on the outer rings of the rollers require an optimised design for the track roller in order to achieve maximum operating life.

Operating data

Operating data		
Load ratio	$F_{r,max}/P_r$	2,2
Speed of rollers	n	$1\,300\text{ min}^{-1}$ to $1\,800\text{ min}^{-1}$

Design solution

The double lever is supported at its centre by cylindrical roller bearings with optimised load carrying capacity of series NJ. Two yoke type track rollers of series NUTR are attached to the lever, one to a cylindrical pin, one to an eccentric pin.

The track roller is preloaded against the cam by the eccentric pin. This preload prevents inertia forces lifting the track rollers at the return point of their oscillating movement.

The enclosed gearbox in which the rollers and the cylindrical roller bearings run is supplied with recirculating oil lubrication.

- ① Yoke type track roller NUTR
- ② Cylindrical roller bearing NJ
- ③ Inner ring IR..EGS

Figure 2
Lay drive
Section A – B

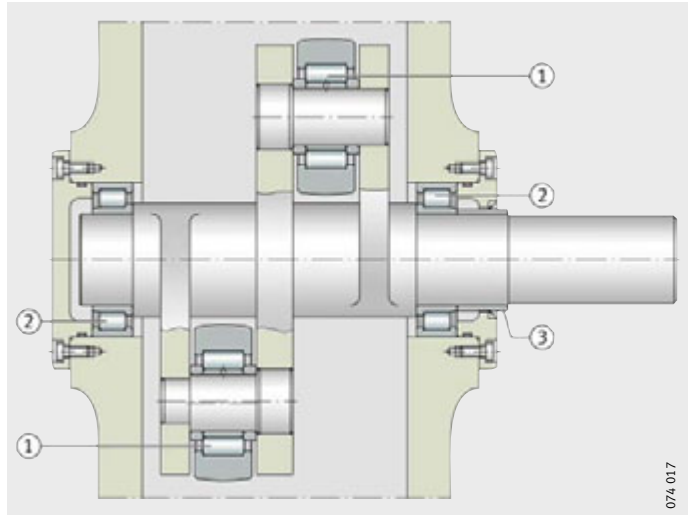

Schaeffler Group products used

- ① Yoke type track roller NUTR (special design)
- ② Cylindrical roller bearing NJ (special design)
- ③ Inner ring IR..EGS (special design).

Weaving machine

Heald frame drive bearing arrangements

In order that a weft can be inserted during weaving in weaving machines, a shed must be opened with the warp threads. The shed is formed by the heald frames holding the warp threads. The possible number of heald frames is between 2 and 28. The frequency at which the up and down movements of the heald frames are reversed determines the texture of the fabric.

The movement of the heald frames is driven by the dobby. The dobby controls the heald frames through a system of linkages and articulated levers.

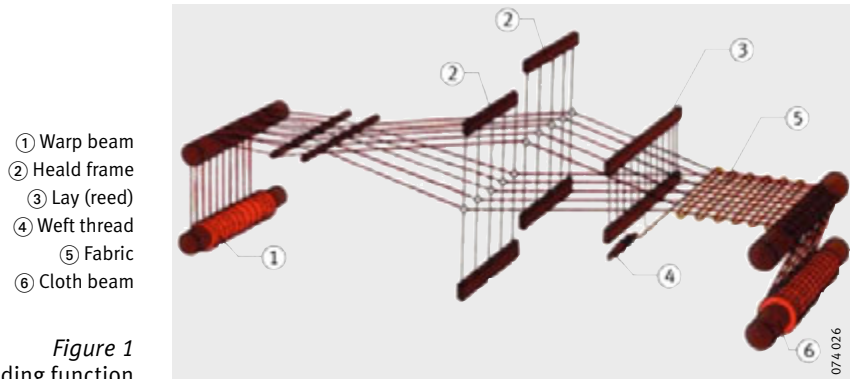

Figure 1
Shedding function

Requirements

In movement of the heald frames, rapid stroke and long shed opening are required since this is the only way to ensure sufficient weft insertion. This movement leads to high shock loads. The clearance in the power flow of the articulation points – in the bearings – should therefore be zero. A compact heald frame depth and small mass are required, so there is only a small design envelope for the width and diameter of the heald frame bearings.

Design solution

The heald frame lever unit comprises a drawn cup needle roller bearing HK and several heald frame bearings.

The drawn cup needle roller bearing has reduced enveloping circle tolerances and is lubricated via a lubrication duct in the shaft.

The heald frame bearing is a full complement bearing and therefore has particularly high load carrying capacity. It is sealed on both sides and greased for life. The radial internal clearance was designed in order to achieve small operating clearance.

Where a very long running time is required, bearings with the solid lubricant Lubtect® are suitable. This is a composite essentially comprising a polymer and a lubricant. Through the use of Lubtect®, lubricants can be held within the bearing with greater stability than in the case of bearings with conventional grease lubrication. The lubricant is supplied more effectively to the contact zone.

This solid lubricant is particularly suitable for heald frame bearing arrangements. In this case, the ball bearing lubricated for life KL would be replaced by the ball bearing KL-L610 with Lubtect®.

- ① Ball bearing KL or KL-L610
- ② Drawn cup needle roller bearing HK
- ③ Roller bearing N
- ④ Needle roller bearing HN

Figure 2
Heald frame

Schaeffler Group products used

- ① Ball bearing KL or KL-L610 (with Lubtect®)
- ② Drawn cup needle roller bearing HK
- ③ Roller bearing N
- ④ Needle roller bearing HN.

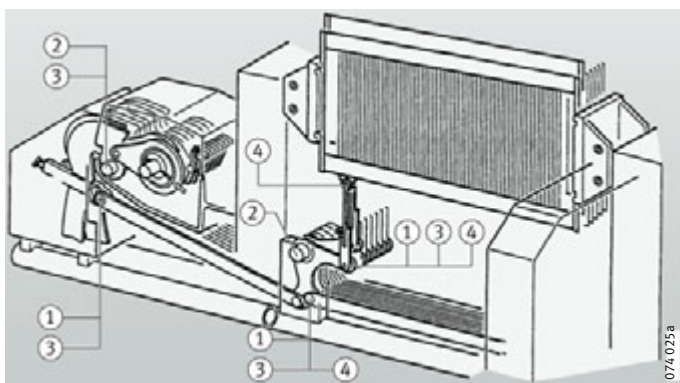

Needle felting machine

Almost everyone walks across them every day: needle felted carpets have “conquered” offices and homes. Furthermore, needled felt does not only demonstrate its good characteristics in laid coverings but also in cars and upholstery.

In the needle felting machine, the loose pile is compacted to the firm, hard-wearing needled felt and the individual fibres are interlocked with each other.



Figure 1
Needle felting machine

Requirements

The needle beams needle into the pile at up to 3 500 strokes per minute. The beam is moved up and down approx. 40 mm by a crankshaft.

The high speeds, large masses and the needling process place extreme loads on the bearings and lead to high temperatures. Nevertheless, a long operating life is required since replacement involves a considerable amount of work.

Design solution

The crankshaft rotates in cage-guided cylindrical roller bearings. The connecting rod pin from which the needle beam is suspended swivels in a full complement cylindrical roller bearing.

One crankshaft has two connecting rods, each supported by a needle roller bearing. The needle roller bearing has an optimised steel cage and is stabilised for high temperatures.

Needle roller bearings are particularly advantageous in this case since they allow high basic load ratings while occupying little space. The accelerations and high speed are supported very well by the bearing when correct lubrication is applied.

The Schaeffler Group needle roller bearings run for long periods in three-shift operation in the needle felting machine.

- ① Special needle roller bearing NA
- ② Special cylindrical roller bearing NCF..-V
- ③ Special cylindrical roller bearing NU

Figure 2
Products

**Schaeffler Group
products used**

- ① Special needle roller bearing NA
- ② Special cylindrical roller bearing NCF..-V
- ③ Special cylindrical roller bearing NU.

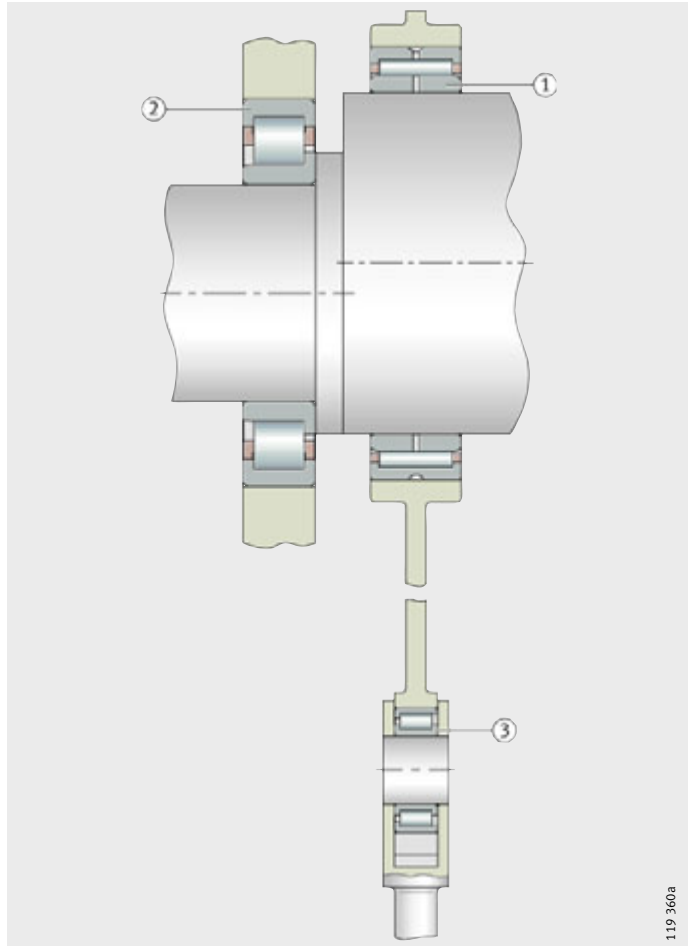

119 360a

Dryer rolls

Materials can be made more refined or more attractive to buy by means of colour, impregnation or other characteristics. One possibility of achieving these characteristics is by treating the finished woven material in a liquid bath.

After this process, the materials will still contain residual moisture that must be removed before further processing. This can be carried out by means of several dryer rolls arranged in series and heated using steam.

Requirements

The balanced dryer rolls, *Figure 1*, rotate at up to 70 min^{-1} . These rolls are heated by steam, increasing the dryer rolls from room temperature to as much as $+170 \text{ }^\circ\text{C}$. Due to the temperature difference of approx. $+150 \text{ }^\circ\text{C}$, the bearing arrangement of the rolls must be able to accommodate differences in length of up to 10 mm. The dryer rolls can be up to six metres long. At this length, deflection must be anticipated, resulting in misalignments.

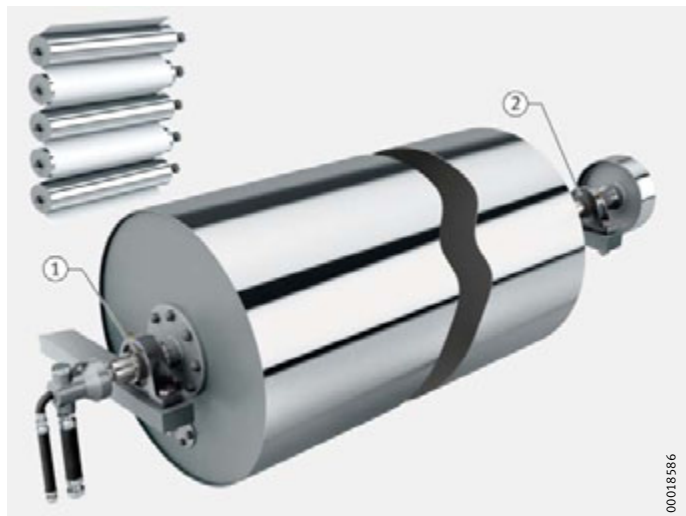

- ① Non-locating bearing RASEY70
- ② Locating bearing RASEY70

Figure 1
Dryer roll

Design solution

The dryer rolls each rotate in two adjustable-angle plummer block housing units RASEY70. The housings contain radial insert ball bearings GYE70-KRR-B sealed by means of gap seals.

Since the housing units have an angular adjustment capability, misalignments can be compensated.

The dryer rolls are driven by means of flat belts. The locating bearing is arranged on the belt pulley side, *Figure 2*. The plummer block housing unit RASEY70 is located on the shaft by means of two grub screws. The grub screws are fitted in the inner ring of the radial insert ball bearing GYE70-KRR-B.

On the non-locating bearing side, where the connections for the superheated steam are arranged, the plummer block housing unit RASEY70 functions as a non-locating bearing, *Figure 2*. In this case, one grub screw of the plummer block housing unit fits in a slot in the shaft but is not clamped against the shaft. As a result, the inner ring of the bearing cannot rotate relative to the shaft. However, the shaft can undergo axial displacement in the inner ring.

The bearings are supplied with a dry preservative. Once they are fitted, they are greased using a special grease. The bearing housings therefore have lubrication nipples through which the grease is pressed into the bearings.

- ① Non-locating bearing RASEY70
- ② Locating bearing RASEY70

Figure 2
Bearing arrangement
of the dryer roll

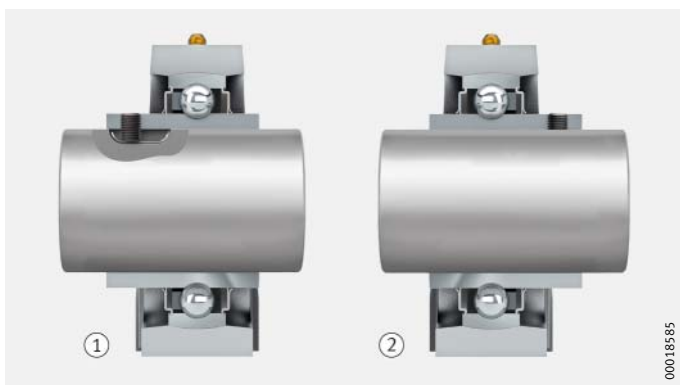

Products used

- ① Plummer block housing unit RASEY70 with radial insert ball bearing GYE70-KRR-B as non-locating bearing
- ② Plummer block housing unit RASEY70 with radial insert ball bearing GYE70-KRR-B as locating bearing.

Addresses

Algeria

Schaeffler Technologies GmbH & Co. KG
FAG Region EMEA (Afrika + Irak)
Georg-Schäfer-Straße 30
97421 Schweinfurt
Germany
Tel. +(49) 97 21 / 91-3253
Fax +(49) 97 21 / 91-3347
Werner.Schindler@schaeffler.com

Andorra

Schaeffler France SAS
93 route de Bitche, BP 30186
67506 Haguenau
France
Tel. +(33) 3 88 63 40 40
Fax +(33) 3 88 63 40 41
info.fr@schaeffler.com

Angola

Schaeffler Technologies GmbH & Co. KG
FAG Region EMEA (Afrika + Irak)
Georg-Schäfer-Straße 30
97421 Schweinfurt
Germany
Tel. +(49) 97 21 / 91-3253
Fax +(49) 97 21 / 91-3347
Werner.Schindler@schaeffler.com

Antigua and Barbuda

Rodamientos FAG, S.A. de C.V.
11511 Interchange Circle South
Miramar, FL 33025
USA
Tel. +(1) 954-7 44 34 44
Fax +(1) 954-7 44 34 76
reinhardt_h@us.fag.com

Argentina

Schaeffler Argentina S.r.l.
Av. Alvarez Jonte 1938
C1416EXR Buenos Aires
Argentina
Tel. +(54) 11 / 40 16 15 00
Fax +(54) 11 / 45 82 33 20
info-ar@schaeffler.com

Armenia

Schaeffler Technologies Representative
Office Ukraine
Jilyanskayastr. 75, 5-er Stock
Business Center «Eurasia»
01032 Kiev
Ukraine
Tel. +(380) 44 593 02 81
Fax +(380) 44 593 02 83
info@schaeffler.kiev.ua

Australia

Schaeffler Australia Pty Limited
Unit 3, 47 Steel Place
Morningside, QLD 4170
Australia
Tel. +(61) 7 / 3399 9161
Fax +(61) 7 / 3399 9351
martin.grosvenor@schaeffler.com

Schaeffler Australia Pty Limited
Suite 14, Level 3
74 Doncaster Road
North Balwyn, VIC 3104
Australia
Tel. +(61) 3 / 9859-8020
Fax +(61) 3 / 9859-8767
milos.grujic@schaeffler.com

Schaeffler Australia Pty Limited
Level 1, Bldg 8,
Forest Central Business Park
49 Frenchs Forest Road
Frenchs Forst, NSW 2086
Australia
Tel. +(61) 2 8977 1000
Fax +(61) 2 9452 4242
info.au@schaeffler.com

Austria

Schaeffler Austria GmbH
Ferdinand-Pözl-Straße 2
2560 Berndorf-St. Veit
Austria
Tel. +43 2672 202-0
Fax +43 2672 202-1003
info.at@schaeffler.com

Azerbaijan

Schaeffler Russland GmbH
Business-Center Avion
125167 Moscow
Russia
Tel. +7 495 73776-60
Fax +7 495 73776-61
info.ru@schaeffler.com

Bahamas

Rodamientos FAG, S.A. de C.V.
11511 Interchange Circle South
Miramar, FL 33025
USA
Tel. +(1) 954-7 44 34 44
Fax +(1) 954-7 44 34 76
reinhardt_h@us.fag.com

Bahrain

Schaeffler Technologies GmbH & Co. KG
Region EMEA (Naher Osten)
Georg-Schäfer-Straße 30
97421 Schweinfurt
Germany
Tel. +(49) 97 21 / 91-35 27
Fax +(49) 97 21 / 91-33 47
Josef.Reiher@schaeffler.com

Bangladesh

Schaeffler Technologies GmbH & Co. KG
Georg-Schäfer-Straße 30
97421 Schweinfurt
Germany
Tel. +(49) 97 21 / 91-48 03
Fax +(49) 97 21 / 91-33 47
Werner.Mauder@schaeffler.com

Barbados

Rodamientos FAG, S.A. de C.V.
11511 Interchange Circle South
Miramar, FL 33025
USA
Tel. +(1) 954-7 44 34 44
Fax +(1) 954-7 44 34 76
reinhardt_h@us.fag.com

Belarus

Schaeffler KG
Repräsentanz Weißrussland
Odoewskogo 117, Raum 317
220015, Minsk
Belarus
Tel. +(375) 17 269 94 81
Fax +(375) 17 269 94 82
fagminsk@mail.bn.by

Belgium

Schaeffler Belgium S.P.R.L./B.V.B.A.
Avenue du Commerce, 38
1420 Braine L'Alleud
Belgium
Tel. +(32) 2 / 3 89 13 89
Fax +(32) 2 / 3 89 13 99
info.be@schaeffler.com

Belize

Rodamientos FAG, S.A. de C.V.
11511 Interchange Circle South
Miramar, FL 33025
USA
Tel. +(1) 954-7 44 34 44
Fax +(1) 954-7 44 34 76
reinhardt_h@us.fag.com

Benin

Schaeffler Technologies GmbH & Co. KG
Georg-Schäfer-Straße 30
97421 Schweinfurt
Germany
Tel. +(49) 97 21 / 91-3253
Fax +(49) 97 21 / 91-3347
Werner.Schindler@schaeffler.com

Bhutan

Schaeffler Technologies GmbH & Co. KG
Georg-Schäfer-Straße 30
97421 Schweinfurt
Germany
Tel. +(49) 97 21 / 91-48 03
Fax +(49) 97 21 / 91-33 47
Werner.Mauder@schaeffler.com

Bolivia

Schaeffler Chile Ltda.
Av. Hernando de Aguirre No. 268 of. 201
Providencia
Santiago
Chile
Tel. +(56) 2 477-5000
Tel. +(56) 2 435-9079
sabine.heijboer@schaeffler.com

Bosnia-Herzegovina

Schaeffler Hrvatska d.o.o.
Ogrizovićeva 28b
10000 Zagreb
Croatia
Tel. +(385) 1 37 01 943
Fax +(385) 1 37 64 473
info.hr@schaeffler.com

Botswana

Schaeffler South Africa (Pty.) Ltd.
1 End Street Ext. Corner Heidelberg Road
2000 Johannesburg
South Africa
Tel. +(27) 11 225 30 00
Fax +(27) 11 334 17 55
info.co.za@schaeffler.com

Brazil

Schaeffler Brasil Ltda.
Av. Independência, 3500-A
Bairro Eden
18087-101 Sorocaba, SP
Brazil
Tel. +(55) 0800 11 10 29
Fax +(55) 15 / 33 35 19 60
sac.br@schaeffler.com

Bulgaria

Schaeffler Bulgaria OOD
Dondukov-Blvd. No 62
Eing. A, 6. Etage, App. 10
1504 Sofia
Bulgaria
Tel. +359 2 946 3900
+359 2 943 4008
Fax +359 2 943 4134
info.bg@schaeffler.com

Burkina Faso

Schaeffler Technologies GmbH & Co. KG
Georg-Schäfer-Straße 30
97421 Schweinfurt
Germany
Tel. +(49) 97 21 / 91-3253
Fax +(49) 97 21 / 91-3347
Werner.Schindler@schaeffler.com

Burundi

Schaeffler Technologies GmbH & Co. KG
Georg-Schäfer-Straße 30
97421 Schweinfurt
Germany
Tel. +(49) 97 21 / 91-3253
Fax +(49) 97 21 / 91-3347
Werner.Schindler@schaeffler.com

Canada

Schaeffler Canada Inc.
Canada Montréal
100 Alexis Nihon Suite 390
Montréal, QC H4M 2N8
Canada
Tel. +(1) 514-748-5111
Tel. +(1) 800-361-5841 Toll Free
Fax +(1) 514-748-6111
info.ca@schaeffler.com

Schaeffler Canada Inc.
Canada Leduc
#106, 7611 Sparrow Drive
Leduc, AB T9E 0H3
Canada
Tel. +(1) 800-663-9006 Toll Free
Tel. +(1) 780-980-3016
Fax +(1) 780-980-3037
info.ca@schaeffler.com

Schaeffler Canada Inc.
Canada Oakville
2871 Plymouth Drive
Oakville, ON L6H 5S5
Canada
Tel. +(1) 905 / 8 29 27 50
Tel. +(1) 800-263-4397 Toll Free
Fax +(1) 905 / 8 29 25 63
info.ca@schaeffler.com

Central African Republic

Schaeffler Technologies GmbH & Co. KG
Georg-Schäfer-Straße 30
97421 Schweinfurt
Germany
Tel. +(49) 97 21 / 91-3253
Fax +(49) 97 21 / 91-3347
Werner.Schindler@schaeffler.com

Chad

Schaeffler Technologies GmbH & Co. KG
Georg-Schäfer-Straße 30
97421 Schweinfurt
Germany
Tel. +(49) 97 21 / 91-3253
Fax +(49) 97 21 / 91-3347
Werner.Schindler@schaeffler.com

Chile

Schaeffler Chile Ltda.
Av. Hernando de Aguirre No. 268 of. 201
Providencia
Santiago
Chile
Tel. +(56) 2 / 477-5000
Fax +(56) 2 / 435-9079
sabine.heijboer@schaeffler.com

China

Schaeffler Holding (China) Co., Ltd.
No. 1 Antuo Road
(west side of Anhong Road)
AnTing, JiaDing District
201804 Shanghai
China
Tel. +86 21 3957 6500
Fax +86 21 3957 6600
www.schaeffler.cn

Schaeffler Trading (Shanghai) Co., Ltd.
No. 1 Antuo Road
(west side of Anhong Road)
AnTing, JiaDing District
201804 Shanghai
China
Tel. +86 21 3957 6000
Fax +86 21 3957 6100
www.schaeffler-aftermarket.cn

Schaeffler Trading (Shanghai) Co., Ltd.
Shanghai Office
No. 1 Antuo Road
(west side of Anhong Road)
AnTing, JiaDing District
201804 Shanghai
China
Tel. +86 21 3957 6500
Fax +86 21 3959 3205
info.cn-shanghai@Schaeffler.com

Schaeffler Hong Kong Co., Ltd.
Unit 3404-5 34/Floor,
Tower One Lippo Center
89 Queensway
Hong Kong
China
Tel. +852 2371 2680
Fax +852 2371 2680
sales_hk@cn.fag.com

Schaeffler Trading (Shanghai) Co., Ltd.
Taiyuan Office
Room 1209, 12th Floor,
Shanxi International Trade Center
West Tower
No. 69 Fuxi Street
030002 Taiyuan, Shanxi
China
Tel. +86 351 8689260
Fax +86 351 8689261
info.cn-taiyuan@Schaeffler.com

Schaeffler Trading (Shanghai) Co., Ltd.
Beijing Branch
RM 2801, Nexus Center, No. 19 A
East 3rd Ring Road North,
Chaoyang District
100020 Beijing
China
Tel. +86 10 6515 0288
Fax +86 10 6512 3433
info.cn-beijing@Schaeffler.com

Schaeffler Trading (Shanghai) Co., Ltd.
Shenyang Office
Unit H/I 14 Floor,
Huaxin International Tower
No.219 Qingnian Avenue,
Shenhe District
110016 Shenyang, Liaoning
China
Tel. +86 24 23962633
Fax +86 24 23962533
info.cn-shenyang@Schaeffler.com

Schaeffler Trading (Shanghai) Co., Ltd.
Dalian Office
Room 0408, MORI Building
No.147 Zhongshan Road, Xigang District
116011 Dalian, Liaoning
China
Tel. +86 411 83681011
Fax +86 411 83681012
info.cn-dalian@Schaeffler.com

Schaeffler Trading (Shanghai) Co., Ltd.
Harbin Office
Unit G 21F, Always Development Plaza
No. 15 Hongjun Street, Nangang
150001 Harbin
China
Tel. +86 451 53009368
Fax +86 451 53009370
www.schaeffler.cn

Addresses

Schaeffler Trading (Shanghai) Co., Ltd.
Nanjing Office
1208 Room, 12F
No.98 South Zhongshan Road
TianAn International Mansion
210008 Nanjing, Jiangsu
China
Tel. +86 25 8312 3070
Fax +86 25 8312 3072
info.cn-nanjing@Schaeffler.com

Schaeffler Trading (Shanghai) Co., Ltd.
Jinan Office
Room 430, CITIC Plaza
No. 150 Luoyuan Avenue
250011 Ji'nan, Shandong
China
Tel. +86 531 8518 0435
Fax +86 531 8518 0438
info.cn-jinan@Schaeffler.com

Schaeffler Trading (Shanghai) Co., Ltd.
Hangzhou Office
Room 1507, Jiahua International
Business Center
No. 15, Hangda Road
310007 Hangzhou, Zhejiang
China
Tel. +86 571 8717 4820/21/22/30
Fax +86 571 8717 4833
www.schaeffler.cn

Schaeffler Trading (Shanghai) Co., Ltd.
Chongqing Office
9-2 Future International Building, No. 6
1st Branch
Jianxin North Road, Jiangbei District
400200 Chongqing
China
Tel. +86 23 67755574
Fax +86 23 67755524
info.cn-chongqing@Schaeffler.com

Schaeffler Trading (Shanghai) Co., Ltd.
Changsha Office
Room 1602, Yunda International Square
No. 478 Rurong Mid.Rd
410001 Changsha, Hunan
China
Tel. +86 731 85139138
Fax +86 731 85467042
info.cn-changsha@Schaeffler.com

Schaeffler Trading (Shanghai) Co., Ltd.
Wuhan Office
Room 3015, New World International
Trade Center
No. 568 Jianshe Avenue,
Jiangnan District
430022 Wuhan, Hubei
China
Tel. +86 27 8526 7335
Fax +86 27 8526 7339
info.cn-wuhan@Schaeffler.com

Schaeffler Trading (Shanghai) Co., Ltd.
Guangzhou Office
Room 1601-2,
Goldlion Digital Network Centre
No. 138 East Tiyu Road
510620 Guangzhou, Guangdong
China
Tel. +86 20 3878 1467
Fax +86 20 8761 0032
www.schaeffler.cn

Schaeffler Trading (Shanghai) Co., Ltd.
Chengdu Office
Room 2815, CCB Sichuan Building
No. 88 Tidu Street
610016 Chengdu, Sichuan
China
Tel. +86 28 8676 6718
Fax +86 28 8676 6728
info.cn-chengdu@Schaeffler.com

Schaeffler Trading (Shanghai) Co., Ltd.
Xi'an Office
Room 1202, HIBC
No. 33 Keji Road, Hi-tech Zone Xi'an City
710075 Xi'an, Shaanxi
China
Tel. +86 29 88337696 99
Fax +86 29 88337707
info.cn-xian@Schaeffler.com

Schaeffler (China) Co., Ltd.
18 Chaoyang Road, Taicang
Jiangsu Province
215400 Taicang, Jiangsu
China
Tel. +86 512 5395 7700
Fax +86 512 5357 4064
info-cn@schaeffler.com

Colombia

FAG Interamericana AG -
Área Colombia-Ecuador
Av. 2Norte - No. 23A-11 - Oficina 208 -
Edificio Unimed
Cali
Colombia
Tel. +(57) 2 / 667 95 82
Fax +(57) 2 / 661 64 20
librejli@schaeffler.com

Costa Rica

INA México, S.A. de C.V. -
Rodamientos FAG, S.A. de C.V.
Henry Ford #141
Col. Bondojito
Deleg. Gustavo A. Madero
07850 Mexico D.F.
Mexico
Tel. +(52) 55 5062 6085
Fax +(52) 55 57 39 58 50
distr.indl.mx@schaeffler.com

Croatia

Schaeffler Hrvatska d.o.o.
Ogrizovičeva 28b
10000 Zagreb
Croatia
Tel. +(385) 1 37 01 943
Fax +(385) 1 37 64 473
info.hr@schaeffler.com

Cuba

INA México, S.A. de C.V.
Rodamientos FAG, S.A. de C.V.
Henry Ford #141
Col. Bondojito
Deleg. Gustavo A. Madero
07850 Mexico D.F.
Mexico
Tel. +(52) 55 5062 6085
Fax +(52) 55 57 39 58 50
distr.indl.mx@schaeffler.com

Czech Republic

Schaeffler CZ s.r.o.
Průběžná 74a
100 00 Praha 10
Czech Republic
Tel. +420 267 298 111
Fax +420 267 298 110
info.cz@schaeffler.com

Denmark

Schaeffler Danmark ApS
Jens Baggesens Vej 90P
8200 Århus N
Denmark
Tel. +(45) 70 15 44 44
Fax +(45) 70 15 22 02
info.dk@schaeffler.com

Djibouti

Schaeffler Technologies GmbH & Co. KG
Georg-Schäfer-Straße 30
97421 Schweinfurt
Germany
Tel. +(49) 97 21 / 91-3253
Fax +(49) 97 21 / 91-3347
Werner.Schindler@schaeffler.com

Dominica

Rodamientos FAG, S.A. de C.V.
11511 Interchange Circle South
Miramar, FL 33025
USA
Tel. +(1) 954-7 44 34 44
Fax +(1) 954-7 44 34 76
reinhardt_h@us.fag.com

Ecuador

ING. Camilo Hidalgo Aguilar.
Colina de los Ceibos Manzana 115
Villa 23
Guayaquil
Ecuador
Tel. +(593) 3-4 2852877
Fax +(593) 3-4 2852877
faginthidalgo@ecuadortelecom.com

Egypt

Delegation Office Schaeffler
Technologies
25, El Obour Buildings - Floor 18 - Flat 4
Salah Salem St.
11371 Cairo
Egypt
Tel. +20 2 24012432
Fax +20 2 22612637
schaeffleregypt@schaeffleregypt.com

El Salvador

INA México, S.A. de C.V. -
Rodamientos FAG, S.A. de C.V.
Henry Ford #141
Col. Bondojito
Deleg. Gustavo A. Madero
07850 Mexico D.F.
Mexico
Tel. +(52) 55 5062 6085
Fax +(52) 55 57 39 58 50
distr.indl.mx@schaeffler.com

Equatorial Guinea

Schaeffler Technologies GmbH & Co. KG
Georg-Schäfer-Straße 30
97421 Schweinfurt
Germany
Tel. +(49) 97 21 / 91-3253
Fax +(49) 97 21 / 91-3347
Werner.Schindler@schaeffler.com

Eritrea

Schaeffler Technologies GmbH & Co. KG
Georg-Schäfer-Straße 30
97421 Schweinfurt
Germany
Tel. +(49) 97 21 / 91-3253
Fax +(49) 97 21 / 91-3347
Werner.Schindler@schaeffler.com

Estonia

Schaeffler Technologies
Repräsenz Baltikum
Duntes iela 23a
1005 Riga
Latvia
Tel. +(371) 7 06 37 95
Fax +(371) 7 06 37 96
info.lv@schaeffler.com

Ethiopia

Schaeffler Technologies GmbH & Co. KG
Georg-Schäfer-Straße 30
97421 Schweinfurt
Germany
Tel. +(49) 97 21 / 91-3253
Fax +(49) 97 21 / 91-3347
Werner.Schindler@schaeffler.com

Fiji

Schaeffler New Zealand
(Unit R, Cain Commercial Centre)
20 Cain Road
1135 Penrose
New Zealand
Tel. +(64) 9 583 1280
Tel. +(64) 021 324 247
(Call out fee applies)
Fax +(64) 9 583 1288
sales.nz@schaeffler.com

Finland

Schaeffler Finland Oy
Lautamiehentie 3
02770 Espoo
Finland
Tel. +(358) 207 / 36 6204
Fax +(358) 207 36 6205
info.fi@schaeffler.com

France

Schaeffler France
93, route de Bitche, BP 30186
67506 Haguenau
France
Tel. +(33) 3 88 63 40 40
Fax +(33) 3 88 63 40 41
info.fr@schaeffler.com

Gabon

Schaeffler Technologies GmbH & Co. KG
Georg-Schäfer-Straße 30
97421 Schweinfurt
Germany
Tel. +(49) 97 21 / 91-3253
Fax +(49) 97 21 / 91-3347
Werner.Schindler@schaeffler.com

Gambia

Schaeffler Technologies GmbH & Co. KG
Georg-Schäfer-Straße 30
97421 Schweinfurt
Germany
Tel. +(49) 97 21 / 91-3253
Fax +(49) 97 21 / 91-3347
Werner.Schindler@schaeffler.com

Georgia

Schaeffler Russland GmbH
Leningradsky Prospekt 47, Bau 3
Business-Center Avion
125167 Moscow
Russia
Tel. +(7) 495 / 7 37 76 60
Fax +(7) 495 / 7 37 76 61
info.ru@schaeffler.com

Germany

Schaeffler Technologies
GmbH & Co. KG
Industriestraße 1-3
91074 Herzogenaurach
Germany
Tel. +(49) 91 32 / 82-0
Fax +(49) 91 32 / 82-4950
info.de@schaeffler.com

Schaeffler Technologies
GmbH & Co. KG
Georg-Schäfer-Str. 30
97421 Schweinfurt
Germany
Tel. +(49) (9721) 91-0
Fax +(49) (9721) 91-3435
faginfo@schaeffler.com
Schaeffler Technologies
GmbH & Co. KG
Geschäftsbereich Lineartechnik
Berliner Straße 134
66424 Homburg (Saar)
Germany
Tel. +49 68 41 / 7 01-0
Fax +49 68 41 / 7 01-2625
info.linear@schaeffler.com

FAG Aerospace GmbH & Co. KG
Georg-Schäfer-Str. 30
97421 Schweinfurt
Germany
Tel. +49 (0 97 21) 91-33 72
astrid.hofmann@schaeffler.com

Ghana

Schaeffler Technologies GmbH & Co. KG
Georg-Schäfer-Straße 30
97421 Schweinfurt
Germany
Tel. +(49) 97 21 / 91-3253
Fax +(49) 97 21 / 91-3347
Werner.Schindler@schaeffler.com

Great Britain

Schaeffler (UK) Ltd
Forge Lane, Minworth
Sutton Coldfield B76 1AP
West Midlands
Great Britain
Tel. +(44) 121 3 13 58 70
Fax +(44) 121 3 13 00 80
info.uk@schaeffler.com

The Barden Corporation (UK) Limited
Plymbridge Road, Estover
Plymouth, PL6 7LH
Great Britain
Tel. +(44) 1752 73 55 55
Fax +(44) 1752 73 34 81
sales@barden.co.uk

Guatemala

INA México, S.A. de C.V. -
Rodamientos FAG, S.A. de C.V.
Henry Ford #141
Col. Bondojoito
Deleg. Gustavo A. Madero
07850 Mexico D.F.
Mexico
Tel. +(52) 55 5062 6085
Fax +(52) 55 57 39 58 50
distr.indl.mx@schaeffler.com

Guinea

Schaeffler Technologies GmbH & Co. KG
Georg-Schäfer-Straße 30
97421 Schweinfurt
Germany
Tel. +(49) 97 21 / 91-3253
Fax +(49) 97 21 / 91-3347
Werner.Schindler@schaeffler.com

Guinea-Bissau

Schaeffler Technologies GmbH & Co. KG
Georg-Schäfer-Straße 30
97421 Schweinfurt
Germany
Tel. +(49) 97 21 / 91-3253
Fax +(49) 97 21 / 91-3347
Werner.Schindler@schaeffler.com

Haiti

Schaeffler Technologies GmbH & Co. KG
Georg-Schäfer-Straße 30
97421 Schweinfurt
Germany
Tel. +(49) 97 21 / 91-3253
Fax +(49) 97 21 / 91-3347
Werner.Schindler@schaeffler.com

Honduras

INA México, S.A. de C.V. -
Rodamientos FAG, S.A. de C.V.
Henry Ford #141
Col. Bondojoito
Deleg. Gustavo A. Madero
07850 Mexico D.F.
Mexico
Tel. +(52) 55 5062 6085
Fax +(52) 55 57 39 58 50
distr.indl.mx@schaeffler.com

Addresses

Hungary

Schaeffler Magyarország Ipari Kft.
Neuman János út 1/B fsz.
1117 Budapest
Hungary
Tel. +(36) 1 / 4 81 30 50
Fax +(36) 1 / 4 81 30 53
budapest@schaeffler.com

Iceland

Schaeffler Technologies GmbH & Co. KG
Georg-Schäfer-Str. 30
97421 Schweinfurt
Germany
Tel. +49 (9721) 91-0
Fax +49 (9721) 91-3435
faginfo@schaeffler.com

India

FAG Bearings India Limited
B-1504, Statesman House, 148,
Barakhamba Road
New Delhi, 110 001
India
Tel. +91 11 237382-77/-78/-76
Tel. +91 11 415214-76/-77
Fax +91 11 51521478
manoj.puri@schaeffler.com

INA Bearings India Pvt. Ltd.
Gahlot Farm House,
Opposite House
No. 525
Sector-47, Haryana
Gurgaon 122001
India
Tel. +91 124 4160600
narayansingh.bora@schaeffler.com

FAG Bearings India Limited
203, Riddhi Siddhi Complex
Madhban
Udaipur 313 001
India
Tel. +91 294 3205482
truptesh.chokshi@schaeffler.com

FAG Bearings India Limited
Maneja
Vadodara 390 013
India
Tel. +91 265 26426-51/-52
Fax +91 265 2 63 88-04/-10
ravinder.mathur@schaeffler.com

FAG Bearings India Limited
Nariman Bhavan, 8th Floor, 227, Back-
bay Reclamation Nariman Point
Mumbai, 400 021
India
Tel. +91 22 2022 144/-166/-362
Fax +91 22 2027022
muratik@fag.co.in

FAG Bearings India Limited
506-A, Surya Kiran Complex
5th Floor, Sarojini Devi Road
Secunderabad 500 003
India
Tel. +91 40 66325522
Fax +91 40 66325523
Mookambeeswaran.nagarajan
@schaeffler.com

FAG Bearings India Limited
18, Gr. Floor, Wst View 77,
R.V. Road, Basavanagudi
Bangalore 560 004
India
Tel. +91 80 2657 5120/-4866
Fax +91 80 26574866
vernon.rego@schaeffler.com

INA Bearings India Pvt. Ltd.
Site No. 1, Sri Nrusimha Towers,
First Floor,
Amruthnagar Main Road
Next to Sub-registrar's Office,
Konanakunte
Bangalore, 560 062
India
Tel. +91 80 4260 6999
Fax +91 80 4260 6922
Sales.bangalore@schaeffler.com

FAG Bearings India Limited
710, 7th Floor, Phase II
Spencer Plaza
769 - Anna Salai
Chennai, 600 002
India
Tel. +91 44 28 4935-82/-83/-84/-85
Fax +91 44 28497577
gnavel.ramalingam@schaeffler.com

FAG Bearings India Limited
Flat No.10, 3rd Floor,
Krishnakamalam Pride Complex
391/392, Bharathiar Road
Coimbatore 641 004
India
Tel. +91 422 2528220
Tel. +91 422 4210080
Fax +91 422 4210080
gopinathan.duraisamy@schaeffler.com

FAG Bearings India Limited
Jasmine Towers, 5th Floor
Room No. 502B, 31
Shakespeare Sarani
Kolkata, 700 017
India
Tel. +91 33 22 8900-26/-27/-96
Tel. +91 33 22 8332 27
Fax +91 33 22 89 00 97
janardhanan.nambiar@schaeffler.com

INA Bearings India Pvt. Ltd.
369, Block 'K' 2nd Floor
New Alipore
Kolkata, 700 053
India
Tel. +91 33 4060 8051
Fax +91 33 4060 8052
chanchal.khan@schaeffler.com

FAG Bearings India Limited
No. 308, 3rd Floor
Akashdeep Plaza, Golmuri
Jamshedpur 831 003
India
Tel. +91 657 2341186
sanjeev.kumar@schaeffler.com

INA Bearings India Pvt. Ltd.
Plot No. A-3 Talegaon Industrial &
Floriculture Park
Village Ambli, Navalakha Umbre,
Taluka Maval
Pune 410 507
India
Tel. +91 20 306104104
Fax +91 20 30614308
info.ina.in@schaeffler.com

Iran

FAG Coordination Office Teheran
No 43/4 Soleiman Khater Ave
Malayeri Pour Cross Rd, 7th of Tir Square
15797 Teheran
Iran
Tel. +(98) 21- 883 63 51
Fax +(98) 21- 830 88 13
fagiran@safineh.net

Iraq

Schaeffler Technologies GmbH & Co. KG
Georg-Schäfer-Straße 30
97421 Schweinfurt
Germany
Tel. +(49) 97 21 / 91-3253
Fax +(49) 97 21 / 91-3347
Werner.Schindler@schaeffler.com

Israel

Schaeffler Technologies GmbH & Co. KG
Georg-Schäfer-Straße 30
97421 Schweinfurt
Germany
Tel. +(49) 97 21 / 91-3253
Fax +(49) 97 21 / 91-3347
Werner.Schindler@schaeffler.com

Italy

Schaeffler Italia S.r.l.
Strada Provinciale 229 Km 17
28015 Momo
Italy
Tel. +(39) 3 21 / 92 92 11
Fax +(39) 3 21 / 92 93 00
info.it@schaeffler.com

Ivory Coast

Schaeffler Technologies GmbH & Co. KG
Georg-Schäfer-Straße 30
97421 Schweinfurt
Germany
Tel. +(49) 97 21 / 91-3253
Fax +(49) 97 21 / 91-3347
Werner.Schindler@schaeffler.com

Japan

Schaeffler Japan Co., Ltd.
New Stage Yokohama
1-132, Shinurashima-cho, Kanagawa-ku,
Yokohama, 221-0031,
Japan
Tel. +81 45 274 8211
Fax +81 45 274 8221
info-japan@schaeffler.com

Korea

Schaeffler Korea Corporation -
Daegu Branch
Shindongyeong Bldg., 17-1
Bukseongno 1-ga Jung-gu,
Daegu, 100-864
Korea
Tel. +(82) 53 - 256-4068
Fax +(82) 53 - 253-5229

Schaeffler Korea Corporation -
Seoul Branch
A-501, 1258, Guro-dong, Guro-gu,
Seoul, 152-721
Korea
Tel. +(82) 2 2625-8572
Fax +(82) 2 2611-6075

Schaeffler Korea Corporation -
Schaeffler Ansan Corporation
1054-2 Shingil-dong, Ansan-shi,
Kyonggi-do, 425-020
Korea
Tel. +(82) 31 / 4 90 69 11
Fax +(82) 31 / 4 94 38 88
info.kr@schaeffler.com

Schaeffler Korea Corporation –
Seobu Branch
402, 3-ga Palbok-dong, Deokjin-gu,
Jeonju-si, Jeollabuk-do, 561-724
Korea
Tel. +(82) 63-211-5770
Fax +(82) 63-211-5791

Schaeffler Korea Corporation –
Busan Branch
577-7, Gwaebeop-dong,
Sasang-gu,
Busan, 617-809
Korea
Tel. +(82) 51 - 328-9386
Fax +(82) 51 - 324-0382

Schaeffler Korea Corporation
Samsung Fire-Marine Insurance Bldg.,
11-12F#87, Euljiro-1ga
Jung-gu, Seoul, 100-191
Korea
Tel. +(82) 2-311-3000
Fax +(82) 2-311-3060
heonkyeong.lee@schaeffler.com

Latvia

Schaeffler Technologies
Repräsentanz Baltikum
Duntes iela 23a
1005 Riga
Latvia
Tel. +(371) 67 06 37 95
Fax +(371) 67 06 37 96
info.lv@schaeffler.com

Lesotho

Schaeffler South Africa (Pty.) Ltd.
1 End Street Ext. Corner Heidelberg Road
2000 Johannesburg
South Africa
Tel. +(27) 11 225 3000
Fax +(27) 11 334 1755
info.co.za@schaeffler.com

Liberia

Schaeffler Technologies GmbH & Co. KG
Georg-Schäfer-Straße 30
97421 Schweinfurt
Germany
Tel. +(49) 97 21 / 91-3253
Fax +(49) 97 21 / 91-3347
Werner.Schindler@schaeffler.com

Libya

Schaeffler Technologies GmbH & Co. KG
Georg-Schäfer-Straße 30
97421 Schweinfurt
Germany
Tel. +(49) 97 21 / 91-3253
Fax +(49) 97 21 / 91-3347
Werner.Schindler@schaeffler.com

Lithuania

Schaeffler Technologies
Repräsentanz Baltikum
Duntes iela 23a
1005 Riga
Latvia
Tel. +(371) 67 06 37 95
Fax +(371) 67 06 37 96
info.lv@schaeffler.com

Luxembourg

Schaeffler Belgium S.P.R.L./B.V.B.A.
Avenue du Commerce, 38
1420 Braine L'Alleud
Belgium
Tel. +(32) 2 / 3 89 13 89
Fax +(32) 2 / 3 89 13 99
info.be@schaeffler.com

Macedonia

Schaeffler Technologies GmbH & Co. KG
Georg-Schäfer-Straße 30
97421 Schweinfurt
Germany
Tel. +(49) 97 21 / 91-32 73
Fax +(49) 97 21 / 91-39 48
Anita.Buehner@schaeffler.com

Madagascar

Schaeffler Technologies GmbH & Co. KG
Georg-Schäfer-Straße 30
97421 Schweinfurt
Germany
Tel. +(49) 97 21 / 91-3253
Fax +(49) 97 21 / 91-3347
Werner.Schindler@schaeffler.com

Malawi

Schaeffler Technologies GmbH & Co. KG
Georg-Schäfer-Str. 30
97421 Schweinfurt
Germany
Tel. +(49) 97 21 / 91-3253
Fax +(49) 21 / 91-3347
Werner.Schindler@schaeffler.com

Malaysia

Schaeffler Bearings (Malaysia) Sdn. Bhd.
5-2 Wisma Fiamma, No. 20 Jalan 7A/62A
Bandar Menjalara
52200 Kuala Lumpur
Malaysia
Tel. +(60) 3-6275 0620
Fax +(60) 3 6275 6421
marketing_my@schaeffler.com

Schaeffler Bearings (Malaysia) Sdn. Bhd.
(Penang Branch)
No. B-02-28, 2nd Floor, Krystal Point
303, Jalan Sultan Azlan Shah
11900 Sungai Nibong
Malaysia
Tel. +(60) 4 642 3708/3781
Fax +(60) 4 642 3724

Maldives

Schaeffler Technologies GmbH & Co. KG
Georg-Schäfer-Straße 30
97421 Schweinfurt
Germany
Tel. +(49) 97 21 / 91-48 03
Fax +(49) 97 21 / 91-33 47
Werner.Mauder@schaeffler.com

Mali

Schaeffler Technologies GmbH & Co. KG
Georg-Schäfer-Straße 30
97421 Schweinfurt
Germany
Tel. +(49) 97 21 / 91-3253
Fax +(49) 97 21 / 91-3347
Werner.Schindler@schaeffler.com

Malta

Schaeffler Technologies GmbH & Co. KG
Georg-Schäfer-Straße 30
97421 Schweinfurt
Germany
Tel. +(49) 97 21 / 91-35 27
Fax +(49) 97 21 / 91-33 47
Josef.Reiher@schaeffler.com

Marshall Islands

Schaeffler New Zealand
(Unit R, Cain Commercial Centre)
20 Cain Road
1135 Penrose
New Zealand
Tel. +(64) 9 583 1280
Tel. +(64) 021 324 247
(Call out fee applies)
Fax +(64) 9 583 1288
sales.nz@schaeffler.com

Mauritania

Schaeffler Technologies GmbH & Co. KG
Georg-Schäfer-Straße 30
97421 Schweinfurt
Germany
Tel. +(49) 97 21 / 91-3253
Fax +(49) 97 21 / 91-3347
Werner.Schindler@schaeffler.com

Addresses

Mauritius

Schaeffler South Africa (Pty.) Ltd.
1 End Street Ext. Corner Heidelberg Road
2000 Johannesburg
South Africa
Tel. +(27) 11 225 3000
Fax +(27) 11 334 1755
info.co.za@schaeffler.com

Mexico

INA México, S.A. de C.V. -
Rodamientos FAG, S.A. de C.V.
Henry Ford #141
Col. Bondojoito
Deleg. Gustavo A. Madero
07850 Mexico D.F.
Mexico
Tel. +(52) 55 5062 6085
Fax +(52) 55 57 39 58 50
distr.indl.mx@schaeffler.com

Micronesia

Schaeffler New Zealand
(Unit R, Cain Commercial Centre)
20 Cain Road
1135 Penrose
New Zealand
Tel. +(64) 9 583 1280
Tel. +(64) 021 324 247
(Call out fee applies)
Fax +(64) 9 583 1288
sales.nz@schaeffler.com

Moldavia

Schaeffler KG Representative
Office Ukraine
Jilyanskayastr. 75, 5-er Stock
Bussines Center «Eurasia»
01032 Kiev
Ukraine
Tel. +(380) 44-593-02-81
Fax +(380) 44-593-02-83
info@schaeffler.kiev.ua

Mongolia

Schaeffler Hong Kong Co., Ltd.
Unit 3404-5, 34/Floor,
Tower One, Lippo Centre
No 89 Queensway
Hong Kong
China
Tel. +(852) 2371/2680
Fax +(852) 2371/2680
sales_hk@cn.fag.com

Morocco

Schaeffler Technologies GmbH & Co. KG
Georg-Schäfer-Straße 30
97421 Schweinfurt
Germany
Tel. +(49) 97 21 / 91-3253
Tel. +(49) 97 21 / 91-3347
Werner.Schindler@schaeffler.com

Mozambique

Schaeffler South Africa (Pty.) Ltd.
1 End Street Ext. Corner Heidelberg Road
2000 Johannesburg
South Africa
Tel. +(27) 11 225 3000
Fax +(27) 11 334 1755
info.co.za@schaeffler.com

Namibia

Schaeffler South Africa (Pty.) Ltd.
1 End Street Ext. Corner Heidelberg Road
2000 Johannesburg
South Africa
Tel. +(27) 11 225 3000
Fax +(27) 11 334 1755
info.co.za@schaeffler.com

Nauru

Schaeffler New Zealand
(Unit R, Cain Commercial Centre)
20 Cain Road
1135 Penrose
New Zealand
Tel. +(64) 9 583 1280
Tel. +(64) 021 324 247
(Call out fee applies)
Fax +(64) 9 583 1288
sales.nz@schaeffler.com

Nepal

Schaeffler Technologies GmbH & Co. KG
Georg-Schäfer-Straße 30
97421 Schweinfurt
Germany
Tel. +(49) 97 21 / 91-48 03
Fax +(49) 97 21 / 91-33 47
Werner.Mauder@schaeffler.com

Netherlands

Schaeffler Nederland B.V.
Gildeweg 31
3771 NB Barneveld
Netherlands
Tel. +(31) 342 / 40 30 00
Fax +(31) 342 / 40 32 80
info.nl@schaeffler.com

New Zealand

Schaeffler New Zealand
(Unit R, Cain Commercial Centre)
20 Cain Road
1135 Penrose
New Zealand
Tel. +(64) 9 583 1280
Tel. +64 021 324 247
(Call out fee applies)
Fax +(64) 9 583 1288
sales.nz@schaeffler.com

Nicaragua

INA México, S.A. de C.V. -
Rodamientos FAG, S.A. de C.V.
Henry Ford #141
Col. Bondojoito
Deleg. Gustavo A. Madero
07850 Mexico D.F.
Mexico
Tel. +(52) 55 5062 6085
Fax +(52) 55 57 39 58 50
distr.indl.mx@schaeffler.com

Niger

Schaeffler Technologies GmbH & Co. KG
Georg-Schäfer-Straße 30
97421 Schweinfurt
Germany
Tel. +(49) 97 21 / 91-3253
Fax +(49) 97 21 / 91-3347
Werner.Schindler@schaeffler.com

Nigeria

Schaeffler Technologies GmbH & Co. KG
Georg-Schäfer-Straße 30
97421 Schweinfurt
Germany
Tel. +(49) 97 21 / 91-3253
Fax +(49) 97 21 / 91-3347
Werner.Schindler@schaeffler.com

Norway

Schaeffler Norge AS
Grenseveien 107
0663 Oslo
Norway
Tel. +(47) 23 24 93 30
Fax +(47) 23 24 93 31
info.no@schaeffler.com

Oman

Schaeffler Technologies GmbH & Co. KG
Georg-Schäfer-Straße 30
97421 Schweinfurt
Germany
Tel. +(49) 97 21 / 91-35 27
Fax +(49) 97 21 / 91-33 47
Josef.Reiher@schaeffler.com

Pakistan

Schaeffler Technologies GmbH & Co. KG
Georg-Schäfer-Straße 30
97421 Schweinfurt
Germany
Tel. +(49) 97 21 / 91-3253
Fax +(49) 97 21 / 91-3347
Werner.Schindler@schaeffler.com
Schaeffler Delegate Office
in Pakistan Karachi
Pakistan
Tel. +(92) 321-251-0068
Pakistan@schaeffler.com

Palau

Schaeffler New Zealand
(Unit R, Cain Commercial Centre)
20 Cain Road
1135 Penrose
New Zealand
Tel. +(64) 9 583 1280
Tel. +(64) 021 324 247
(Call out fee applies)
Fax +(64) 9 583 1288
sales.nz@schaeffler.com

Panama

INA México, S.A. de C.V. -
Rodamientos FAG, S.A. de C.V.
Henry Ford #141
Col. Bondojito
Deleg. Gustavo A. Madero
07850 Mexico D.F.
Mexico
Tel. +(52) 55 5062 6085
Fax +(52) 55 57 39 58 50
distr.indl.mx@schaeffler.com

Papua New Guinea

Schaeffler Australia Pty Ltd
Level 1, Bldg 8
Forest Central Business Park
49 Frenchs Forest Road
Frenchs Forest, NSW 2086
Australia
Tel. +(61) 2-89 77 10 00
Fax +(61) 2-94 52 42 42
info.au@schaeffler.com

Paraguay

Schaeffler Brasil Ltda.
Av. Independência, 3500-A
Bairro Eden
18087-101 Sorocaba, SP
Brazil
Tel. 0800 11 10 29
Fax +(55) 15 / 33 35 19 60
sac.br@schaeffler.com

Peru

Schaeffler Chile Ltda
Av. Hernando de Aguirre No. 268 of. 201
Providencia
Santiago
Chile
Tel. +(56) 2 / 477-5000
Fax +(56) 2 / 435-9079
sabine.heijboer@schaeffler.com

Philippines

Schaeffler Philippines Inc
5th Floor, Optima Building
221 Salcedo Street, Legaspi Village
1229 Makati City
Philippines
Tel. +(63) 2 759 3583
Fax +(63) 2 759 3578
marketing_ph@schaeffler.com

Schaeffler Philippines Inc - Branch Office
Unit A- 202, S.A Bldg.
Plaridel St., Alang-Alang
Mandaue City
Philippines
Tel. +(63) 32 2362404
Fax +(63) 32 3443644

Poland

Schaeffler Polska Sp. z o.o.
Budynek E
ul. Szyszkowa 35/37
02-285 Warszawa
Poland
Tel. +(48) 22 / 8 78 41 20
Fax +(48) 22 / 8 78 41 22
info.pl@schaeffler.com

Portugal

INA Rolamentos Lda.
Arrábida Lake Towers
Rua Daciano Baptista Marques Torre C,
181, 2^o piso
4400-617 Vila Nova de Gaia
Portugal
Tel. +(351) 22 / 5 32 08 00
Fax +(351) 22 / 5 32 08 60
info.pt@schaeffler.com

Romania

S.C. Schaeffler Romania S.R.L.
Aleea Schaeffler Nr. 3
507055 Cristian/Brasov
Romania
Tel. +(40) 268 505808
Fax +(40) 268 505848
info.ro@schaeffler.com

Russia

Schaeffler Russland GmbH
Leningradsky Prospekt 47, Bau 3
Business-Center Avion
125167 Moscow
Russia
Tel. +7 495 7 37 76 60
Fax +7 495 7 37 76 61
info.ru@schaeffler.com

Schaeffler Russland GmbH
Sverdlovskaya Embankment 44,
Letter SH
BC "Benua", office 207
195027 St. Petersburg
Russia
Tel. +7 812 633 3644
Fax +7 812 633 3645
info.spb@schaeffler.com

Schaeffler Russland GmbH
ul. 1 Maya 91/1
350901 Krasnodar
Russia
Tel. +7 918 142 96 73
Fax +7 918 142 96 73

Schaeffler Russland GmbH
ul. Marshala Zhukova 35, Floor 4,
Office 5
445051 Togliatti
Russia
Tel. +7 8482 93 13 22
Fax +7 8482 93 13 22

Schaeffler Russland GmbH
ul. Yadrintseva 53/1, Office 909
630090 Novosibirsk
Russia
Tel. +7 383 218 83 60
Fax +7 383 218 83 59

Rwanda

Schaeffler Technologies GmbH & Co. KG
Georg-Schäfer-Straße 30
97421 Schweinfurt
Germany
Tel. +(49) 97 21 / 91-3253
Fax +(49) 97 21 / 91-3347
Werner.Schindler@schaeffler.com

Samoa

Schaeffler New Zealand
(Unit R, Cain Commercial Centre)
20 Cain Road
1135 Penrose
New Zealand
Tel. +(64) 9 583 1280
Tel. +(64) 021 324 247
(Call out fee applies)
Fax +(64) 9 583 1288
sales.nz@schaeffler.com

São Tomé and Príncipe

Schaeffler Technologies GmbH & Co. KG
Georg-Schäfer-Straße 30
97421 Schweinfurt
Germany
Tel. +(49) 97 21 / 91-3253
Fax +(49) 97 21 / 91-3347
Werner.Schindler@schaeffler.com

Saudi Arabia

Schaeffler Technologies GmbH & Co. KG
Georg-Schäfer-Straße 30
97421 Schweinfurt
Germany
Tel. +(49) 97 21 / 91-35 27
Fax +(49) 97 21 / 91-33 47
Josef.Reiher@schaeffler.com

Senegal

Schaeffler Technologies GmbH & Co. KG
Georg-Schäfer-Straße 30
97421 Schweinfurt
Germany
Tel. +(49) 97 21 / 91-3253
Fax +(49) 97 21 / 91-3347
Werner.Schindler@schaeffler.com

Serbia

Schaeffler Technologies
Repräsentanz Serbien
Branka Krsmanovica 12
11118 Beograd
Serbia
Tel. +(381) 11 308 87 82
Fax +(381) 11 308 87 75
fagbgdyu@sezampro.yu

Seychelles

Schaeffler South Africa (Pty.) Ltd.
1 End Street Ext. Corner Heidelberg Road
2000 Johannesburg
South Africa
Tel. +(27) 11 225 3000
Fax +(27) 11 334 17 55
info.co.za@schaeffler.com

Sierra Leone

Schaeffler Technologies GmbH & Co. KG
Georg-Schäfer-Straße 30
97421 Schweinfurt
Germany
Tel. +(49) 97 21 / 91-3253
Fax +(49) 97 21 / 91-3347
Werner.Schindler@schaeffler.com

Addresses

Singapore

Schaeffler (Singapore) Pte. Ltd.
151 Lorong Chuan, #06-01
New Tech Park, Lobby A
556741 Singapore
Singapore
Tel. +(65) 6540 8600
Fax +(65) 6540 8668
info.sg@schaeffler.com

Slovak Republic

Schaeffler Slovensko, spol. s.r.o.
Ulica Dr. G. Schaefflera 1
02401 Kysucké Nové Mesto
Slovak Republic
Tel. +(421) 41 / 4 20 59 11
Fax +(421) 41 / 4 20 59 18
info.sk@schaeffler.com

Schaeffler Slovensko, spol.s.r.o.
Nevádzova 5
821 01 Bratislava
Slovak Republic
Tel. +(421) 2 43 294 260
Fax +(421) 2 48 287 820
fag@fag.sk

Slovenia

Schaeffler Slovenija d.o.o.
Glavni trg 17/b
2000 Maribor
Slovenia
Tel. +(386) 2 / 22 82-070
Fax +(386) 2 / 22 82-075
info.si@schaeffler.com

Solomon Islands

Schaeffler New Zealand
(Unit R, Cain Commercial Centre)
20 Cain Road
1135 Penrose
New Zealand
Tel. +(64) 9 583 1280
Tel. +(64) 021 324 247
(Call out fee applies)
Fax +(64) 9 583 1288
sales.nz@schaeffler.com

Somalia

Schaeffler South Africa (Pty.) Ltd.
1 End Street Ext. Corner Heidelberg Road
2000 Johannesburg
South Africa
Tel. +(27) 11 225 3000
Fax +(27) 11 334 1755
info.co.za@schaeffler.com

South Africa

Schaeffler South Africa (Pty.) Ltd.
1 End Street Ext. Corner Heidelberg Road
2000 Johannesburg
South Africa
Tel. +(27) 11 225 3000
Fax +(27) 11 334 1755
info.co.za@schaeffler.com

Spain

Schaeffler Iberia, s.l.u.
Polígono Ind. Pont Reixat
08960 Sant Just Desvern
Spain
Tel. +(34) 93 / 4 80 34 10
Fax +(34) 93 / 3 72 92 50
info.es@schaeffler.com

Sri Lanka

Schaeffler Technologies GmbH & Co. KG
Georg-Schäfer-Straße 30
97421 Schweinfurt
Germany
Tel. +(49) 97 21 / 91-48 03
Fax +(49) 97 21 / 91-33 47
Werner.Mauder@schaeffler.com

St. Kitts and Nevis

Rodamientos FAG, S.A. de C.V.
11511 Interchange Circle South
Miramar, FL 33025
USA
Tel. +(1) 954-7 44 34 44
Fax +(1) 954-7 44 34 76
reinhardt_h@us.fag.com

St. Lucia

Rodamientos FAG, S.A. de C.V.
11511 Interchange Circle South
Miramar, FL 33025
USA
Tel. +(1) 954-7 44 34 44
Fax +(1) 954-7 44 34 76
reinhardt_h@us.fag.com

St. Vincent and the Grenadines

Rodamientos FAG, S.A. de C.V.
11511 Interchange Circle South
Miramar, FL 33025
USA
Tel. +(1) 954-7 44 34 44
Fax +(1) 954-7 44 34 76
reinhardt_h@us.fag.com

Sudan

Schaeffler Technologies GmbH & Co. KG
Georg-Schäfer-Straße 30
97421 Schweinfurt
Germany
Tel. +(49) 97 21 / 91-3253
Fax +(49) 97 21 / 91-3347
Werner.Schindler@schaeffler.com

Surinam

Schaeffler Brasil Ltda.
Av. Independência, 3500-A
Bairro Eden
18087-101 Sorocaba, SP
Brazil
Tel. 0800 11 10 29
Fax +(55) 15 / 33 35 19 60
sac.br@schaeffler.com

Swaziland

Schaeffler South Africa (Pty.) Ltd.
1 End Street Ext. Corner Heidelberg Road
2000 Johannesburg
South Africa
Tel. +(27) 11 225 3000
Fax +(27) 11 334 1755
info.co.za@schaeffler.com

Sweden

Schaeffler Sverige AB
Charles gata 10
195 61 Arlandastad
Sweden
Tel. +(46) 8 / 59 51 09 00
Fax +(46) 8 / 59 51 09 60
info.se@schaeffler.com

Switzerland

HYDREL GmbH
Badstrasse 14
8590 Romanshorn
Switzerland
Tel. +(41) 71 / 4 66 66 66
Fax +(41) 71 / 4 66 63 33
info.ch@schaeffler.com

Syria

Schaeffler Technologies GmbH & Co. KG
Georg-Schäfer-Straße 30
97421 Schweinfurt
Germany
Tel. +(49) 97 21 / 91-3253
Fax +(49) 97 21 / 91-3347
Werner.Schindler@schaeffler.com

Tadzhikistan

Schaeffler Russland GmbH
Leningradsky Prospekt 47, Bau 3
Business-Center Avion
125167 Moscow
Russia
Tel. +7 495 7 37 76 60
Fax +7 495 7 37 76 61
info.ru@schaeffler.com

Taiwan

Schaeffler Taiwan Co.
9F-6 No.188 Sec.5, Nanjing E. Road, 105
Taipei
Taiwan
Tel. +886 2 7707 9888
Fax +886 2 2747 9926
info.tw@schaeffler.com

M.Hsieh's Industry Corp.
1 F, No. 121, Section 1
Heping East Road
Taipei 10644
Taiwan
Tel. +886 2 3322 5699
Fax +886 2 3322 5700
mhina@mhina.com.tw

Tanzania

Schaeffler Technologies GmbH & Co. KG
Georg-Schäfer-Straße 30
97421 Schweinfurt
Germany
Tel. +(49) 97 21 / 91-3253
Fax +(49) 97 21 / 91-3347
Werner.Schindler@schaeffler.com

Thailand

Schaeffler (Thailand) Co., Ltd.
388 Exchange Tower, 34th Floor
Sukhumvit Road, Klongtoey
Bangkok, 10110
Thailand
Tel. +(66) 2697 0000
Fax +(66) 2697 0001
info.th@schaeffler.com

Togo

Schaeffler Technologies GmbH & Co. KG
Georg-Schäfer-Straße 30
97421 Schweinfurt
Germany
Tel. +(49) 97 21 / 91-3253
Fax +(49) 97 21 / 91-3347
Werner.Schindler@schaeffler.com

Tonga

Schaeffler New Zealand
(Unit R, Cain Commercial Centre)
20 Cain Road
1135 Penrose
New Zealand
Tel. +(64) 9 583 1280
Tel. +(64) 021 324 247
(Call out fee applies)
Fax +(64) 9 583 1288
sales.nz@schaeffler.com

Trinidad and Tobago

INA México, S.A. de C.V. -
Rodamientos FAG, S.A. de C.V.
Henry Ford #141
Col. Bondojito
Deleg. Gustavo A. Madero
07850 Mexico D.F.
Mexico
Tel. +(52) 55 5062 6085
Fax +(52) 55 57 39 58 50
distr.indl.mx@schaeffler.com

Tunisia

FAG AFRIQUE DU NORD
66 Avenue de Carthage
1000 Tunis
Tunisia
Tel. +(216) 1 / 34 14 48
Tel. +(216) 1 / 33 67 04
fagafriquedunord@socoopec.com.tn

Turkey

Schaeffler Rulmanlari Ticaret Limited
Sirketi
Aydin Sokak Dagli Apt. 4/4
1. Levent
34340 Istanbul
Turkey
Tel. +90 212 2 79 27 41
Tel. +90 212 280 77 98
Fax +90 212 2 81 66 45
Fax +90 212 280 94 45
info.tr@schaeffler.com

Turkmenistan

Schaeffler Russland GmbH
Leningradsky Prospekt 47, Bau 3
Business-Center Avion
125167 Moscow
Russia
Tel. +(7) 495 / 7 37 76 60
Fax +(7) 495 / 7 37 76 61
info.ru@schaeffler.com

Tuvalu

Schaeffler New Zealand
(Unit R, Cain Commercial Centre)
20 Cain Road
1135 Penrose
New Zealand
Tel. +(64) 9 583 1280
Tel. +(64) 021 324 247
(Call out fee applies)
Fax +(64) 9 583 1288
sales.nz@schaeffler.com

Uganda

Schaeffler Technologies GmbH & Co. KG
Georg-Schäfer-Straße 30
97421 Schweinfurt
Germany
Tel. +(49) 97 21 / 91-3253
Fax +(49) 97 21 / 91-3347
Werner.Schindler@schaeffler.com

Ukraine

Schaeffler Technologies
Representative Office Ukraine
Jilyanskayastr. 75, 5-er Stock
Bussines Center «Eurasia»
01032 Kiev
Ukraine
Tel. +(380) 44-593-02-81
Fax +(380) 44-593-02-83
info@schaeffler.kiev.ua

UAE United Arab Emirates

Schaeffler Middle East FZE
Road SE101, Schaeffler Building
Jebel Ali Free Zone - Southside
Dubai UAE
UAE United Arab Emirates
Tel. +971 4 81 44 500
Fax +971 4 81 44 601
ousama.abukhader@schaeffler.com

Samir Odeh & Sons
Airport Road
P.O. Box 12991
Dubai
UAE United Arab Emirates
Tel. +971 42 82 17 62
Fax +971 42 82 17 78
info@sosgroup.ae

Uruguay

Schaeffler Argentina S.r.l
Av. Alvarez Jonte 1938
C1416EXR Buenos Aires
Argentina
Tel. +(54) 11 / 40 16 15 00
Fax +(54) 11 / 45 82 33 20
info-ar@schaeffler.com

USA

Schaeffler Group USA Inc.
200 Park Avenue
P.O. Box 1933
Danbury, CT 06813-1933
USA
Tel. +1 203 790 54 74
Fax +1 203 830 81 71
Diana.DiBartolomeo@schaeffler.com

The Barden Corporation
200 Park Avenue
P.O. Box 2449
Danbury, CT 06813-2449
USA
Tel. +1 0203 744 22 11
Fax +1 0203 744 37 56
Diana.DiBartolomeo@schaeffler.com

Schaeffler Group USA Inc.
308 Springhill Farm Road
Fort Mill, SC 29715
USA
Tel. +1 803 548 8500
Fax +1 803 548 8599
info.us@schaeffler.com

Schaeffler Group USA Inc.
5370 Wegman Drive
Valley City, OH 44280-9700
USA
Tel. +1 800 274 5001
Fax +1 330 273 3522
luk-ina-fag-as.us@schaeffler.com

Addresses

Uzbekistan

Schaeffler Russland GmbH
Leningradsky Prospekt 47, Bau 3
Business-Center Avion
125167 Moscow
Russia
Tel. +(7) 495 / 7 37 76 60
Fax +(7) 495 / 7 37 76 61
info.ru@schaeffler.com

Vanuatu

Schaeffler New Zealand
(Unit R, Cain Commercial Centre)
20 Cain Road
1135 Penrose
New Zealand
Tel. +(64) 9 583 1280
Tel. +(64) 021 324 247
(Call out fee applies)
Fax +(64) 9 583 1288
ana.acevedo@schaeffler.com

Venezuela

Schaeffler Venezuela C.A.
Urbanización San José de Tarbes
Torre BOD, Piso 14, Oficina 14-1
Valencia
Venezuela
Tel. +58 58 241 825 4747
Fax +58 58 241 825 9705
christian.ommundsen@schaeffler.com

Vietnam

Schaeffler Vietnam Co., Ltd
TMS Building, 6th Floor
172 Hai Ba Trung street, District 1
Ho Chi Minh City
Vietnam
Tel. +84 8 22 20 2777
Fax +84 8 22 20 2776
marketing_vn@schaeffler.com

Schaeffler Vietnam Co., Ltd
VCCI building, 3th floor, unit 319
No.9 Dao Duy Anh street – Dong Da Dist
Ha Noi
Vietnam
Tel. +84 4 577 1792
Fax +84 4 577 1791

Zambia

Schaeffler South Africa (Pty.) Ltd.
1 End Street Ext. Corner Heidelberg Road
2000 Johannesburg
South Africa
Tel. +(27) 11 225 3000
Fax +(27) 11 334 1755
info.co.za@schaeffler.com

Zimbabwe

Schaeffler South Africa (Pty.) Ltd.
1 End Street Ext. Corner Heidelberg Road
2000 Johannesburg
South Africa
Tel. +(27) 11 225 3000
Fax +(27) 11 334 1755
info.co.za@schaeffler.com

**Schaeffler Technologies
GmbH & Co. KG**

Industriestraße 1–3
91074 Herzogenaurach
Germany
Internet www.ina.com
E-Mail info@schaeffler.com

In Germany:

Phone 0180 5003872
Fax 0180 5003873

From other countries:

Phone +49 9132 82-0
Fax +49 9132 82-4950

**Schaeffler Technologies
GmbH & Co. KG**

Georg-Schäfer-Straße 30
97421 Schweinfurt
Germany
Internet www.fag.com
E-Mail FAGinfo@schaeffler.com

In Germany:

Phone 0180 5003872
Fax 0180 5003873

From other countries:

Phone +49 9721 91-0
Fax +49 9721 91-3435

Every care has been taken to ensure the correctness of the information contained in this publication but no liability can be accepted for any errors or omissions. We reserve the right to make technical changes.

© Schaeffler Technologies GmbH & Co. KG
Issued: 2011, August

This publication or parts thereof may not be reproduced without our permission.
TMB GB-D